



RS-110-DP

**BACK COVER
PRINTER'S NOTE:
production back cover
is to be printed with gray
scale front cover; this is a
place marker cover.**

INSTALLATION INSTRUCTIONS

**FRONT COVER
PRINTER'S NOTE:
production front cover
is gray scale; this is a
place marker cover.**

COPYRIGHT 2007: OMEGA RESEARCH & DEVELOPMENT, INC.

Contents

Installation Considerations/Component Mounting	3-4
Status light & Valet Switch mounting	4
Main Wiring Harness	5-7
Red & Red/White wires (+12V input)	5
Pink wire (+Ign. #1 output)	6
Orange wire (+ACC output)	6-7
Violet wire (+Start output)	7
Pink/White wire (+Ign. #2/Programmable output)	7
Secondary Wiring Harness	8-16
Black wire (Ground input)	8
Orange wire (-Anti-grind output)	8-9
Brown/Red wire (+Brake input)	9
Black/White wire (-Neutral Safety input)	9-10
Violet/White wire (Tach input)	10-11
White/Blue wire (-Remote Start Activation input)	11
White wire (+Light output)	11, 14
Wiring Diagram/Overview	12-13
White/Black wire (-Light output)	14-15
Gray wire (-Hood input)	15
Yellow wire (+Ext. Alarm ACC power control output)	16
Lt. Green/Black wire (-OEM alarm disarm output)	16
Lt. Green/Red wire (-OEM alarm arm output)	16
Remote Start Satellite Relay Port	17
Data Port	17
User Programmable Features	18
Installer Programmable Features	18-21
Programming Features	22-23
Programmable Features Matrix	23

Step 7 Allow 10 seconds to pass without performing any programming actions, or turn the vehicle's ignition on.

- The Status Light & parking lights will turn off.

Complete Programmable Features Matrix

USER Features		Ignition on, off, then press Valet Switch 5 times (BLUE Status Light).			
#	Feature	Brake Pedal x 1	Brake Pedal x 2	Brake Pedal x 3	Brake Pedal x 4
1	Remote Start Run Time	10 Min.	5 min.	15 min.	20 min.
2	Steady/Flash Lights Rem. Start	Steady	Flashing		
INSTALLER Features		Ignition on, off, then press Valet Switch 10 times (BLUE Status Light).			
1	Remote Start Activation Pulses	1	2	3	4
2	"Tach Wire" or "Tachless "	Tachless	Tach	Data Tach	
3	Gasoline or Diesel Engine	Gasoline	Diesel		
4	Sat. Port Green Wire Function	Starter	Pulse After Start	Pulse After Stop	Accessory Output
5	Ext. Starter Cranking Time	.7 (minimum)	1.25	1.75	2.5 (maximum)
6	N/A				
7	Turbo Timer	OFF	1 min.	2 min.	3 min.

INSTALLER Hardware Programmable Feature

Below are the jumper settings for choosing the operation of the Pink/White remote start output wire.

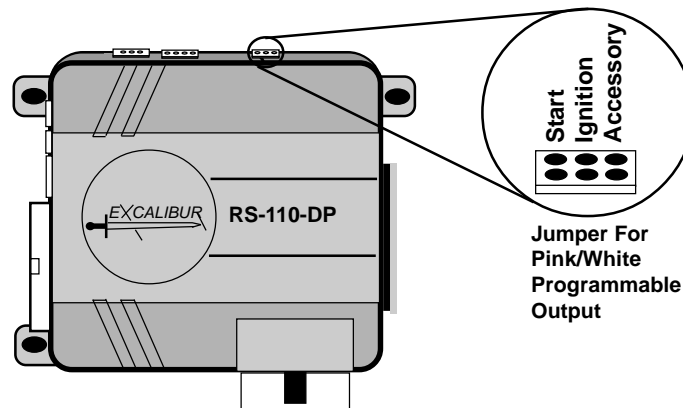

The Excalibur RS-110-DP's 1-way transmitters are pre-programmed at the factory to operate the system. If adding or replacing transmitters, **please see the Operation Guide booklet for Transmitter programming.**

Programming Features

Step 1	Turn the vehicles's ignition on.
Step 2	Turn the ignition off.
Step 3	<u>Within 5 seconds, Press & Release the Valet Switch</u> 5 times for User Programming (Solid Blue Status Light) OR 10 times for Installer Programming (Solid Blue Status Light)

- The Status Light & parking lights will turn on to confirm that the system has entered Programming Mode.
- In the case of accessing the Installer Mode, the lights will turn on at the fifth valet switch press, immediately turn off at the sixth valet press, and then turn on again at the tenth valet switch press.
- In either Programming Mode, if 10 seconds of no programming activity occurs, the system will exit Programming Mode.

Access a Feature:

Step 4	<u>Within 10 seconds, Press & Release the Valet Switch the same number of times as the desired feature's number.</u>
---------------	--

- The Status Light & parking lights will flash equal to the number of the selected feature. The Status Light will continue to flash in the same manner with a brief pause between each flashing sequence.

Change the Feature:

Step 5	After accessing the desired feature, <u>within 10 seconds</u> Press & Release the brake pedal equal to the option desired.
---------------	--

- Pressing the brake pedal **once** typically turns the feature on; or sets the feature's first option. The Status Light and the parking lights will flash once when this option is chosen.
- Pressing brake pedal **twice** also typically turns the feature off; or, sets the feature's second option. The Status Light and the parking lights will flash twice.
- Many features have third, and even fourth setting options. Pressing the brake pedal 3 or 4 times will select these options. Status Light & parking lights flash three or four times respectively.

To Access and Change further Features:

Step 6	If there are more features to be programmed, <u>within 10 seconds</u> of the previous action Press & Release the Valet Switch the same number of times as the next desired feature's number.
---------------	--

- Again the Status Light and parking lights will flash as many times as the Valet Switch was pressed to indicate the new feature number which is now accessed. Then press the brake pedal as described in Step 5 to change the newly accessed feature as desired.

- IMPORTANT -

Please carefully read these instructions before starting the installation of the Excalibur RS-110-DP. The numerous wiring connections required, and the options offered by several of the programmable features makes pre-planning the installation critical.

The included hood pin switch MUST be installed.

The remote engine starting feature should not be used when the vehicle is parked in an enclosed structure or garage!

More complete instructions for programming transmitters and features may be found in the Operation Manual.

Installation Considerations

Before Starting The Installation: This entire booklet should be read before starting the installation. An understanding of which control module wires are to be used and their functions is essential. Installations will vary from car to car, as some control module wire connections are required, while others are optional. Before starting the installation, it should be determined which control module wires will be used. Most installers will list these wires, then "map out" the installation by locating and noting the target wires in the vehicle. This will also determine the best location for the control module, which is mounted upon completion of the installation and testing of the system.

For remote starting operation, the Excalibur RS-110-DP duplicates, with on-board microprocessor control circuitry and relays, the same actions that occur within the ignition switch as when the key is used to start the engine. Because of this, most of the main wiring harness connections will be made at the ignition switch harness. This will be located around the steering column area.

CAUTION! Avoid the Airbag circuit! Especially avoid any harness or wires encased in Yellow or Red tubing or sleeves. Do not use a standard test light, as it can deploy an airbag or damage on-board computers and sensors if the wrong circuits are probed. A Digital Multimeter (DMM) should be used.

The ignition switch wires typically are high amperage circuits, which means that high reliability connections must be made! Proper soldering of all connections is recommended.

Mounting The Control Module: The Control Module contains the necessary electronics required for the system's operation. Always mount this module in the vehicle's interior compartment, in a secure location that is not easily accessible. Ensure that moisture, vibration and temperature extremes are minimized. Acceptable locations include mounting behind the dash, behind the glovebox or other interior panels.

Status Light and Valet Switch: Carefully select locations in which the valet switch may be easily reached and the status light may be easily seen. The status light's location will need clear space behind the panel in which it is mounted for proper routing of the wire harness. The status light requires a 9/32" hole to be drilled for proper mounting. The valet switch has a double stick pad that can be utilized. a 1/4" hole can be drilled to hide and route the wire harness underneath the valet switch. Optionally, there is a black plastic mounting disc included with the system that provides a clean secure surface for the valet switch. It can be mounted to the dash with the included mounting screw. After mounting these components in the vehicle, route their harnesses to the main module and plug them into the appropriate ports.

Data Port for OmegaLink & IntelliKit Modules: Most Omega data bus interface modules and bypass kits simply plug into this port. These data-to-data (D2D) accessory products save time, and in many cases offer the only acceptable interface means for many newer vehicle's doorlocking system and/or for the OEM-antitheft bypass when adding an alarm or remote starting. Omega offers the industries most comprehensive line of these products (go to www.caralarm.com for latest application guide), and each includes its own vehicle-specific instructions.

Remote Start Relay Capability & Satellite Port: The RS-110-DP features 4 dedicated, built-in high-ampereage relays for remote starting; one of these is even programmable. And, there is another form of adding additional remote starting outputs via plug-in satellite relay port for the optional RS-RP outboard relay pack (start and ignition operation). This port is also used to activate any analog type of immobilizer bypass module.

- The second setting will give a 0.8 second pulse immediately after the large Violet wire's output stops.
- The third setting will give a 0.8 second pulse immediately after the remote start shuts down by any means.
- The fourth setting operates as a secondary ACCESSORY output. This will have the same operation as the large Orange wire on the main harness. **This feature should only be programmed by the installer.**

Feature #5 Extended Starter Cranking Time

Factory Default Setting **Minimum (.7 Second)**
(press brake pedal **1x** to program)

Options:

Medium Lo (1.25 Second) (press brake pedal **2x** to program)

Medium Hi (1.75 Second) (press brake pedal **3x** to program)

Maximum (2.5 Second) (press brake pedal **4x** to program)

Extended Starter Cranking Time operates in conjunction with the feature #2's "Tachless" setting. When the system is set for "Tachless", this feature sets the duration of the starter output's for the 1st start attempt. If the engine doesn't start on the first attempt, the system will retry up to 3 more times. With each attempt, the output will be extended by 0.2 seconds. There are four different base starter output settings. While the default-set minimum is sufficient for most vehicles; the Extended Starter Cranking Time can be used for difficult-to-start engines. **This feature should only be programmed by the installer.**

Feature #6 NOT AVAILABLE

Feature #7 Turbo Timer

Factory Default Setting **Off**
(press brake pedal **1x** to program)

Options:

Run 1 Minute (press brake pedal **2x** to program)

Run 2 Minutes (press brake pedal **3x** to program)

Run 3 Minutes (press brake pedal **4x** to program)

This feature when turned on configures the RS-110-DP to automatically keep the engine running briefly after it is turned off. This operation is designed specifically for vehicles having turbocharged engines (the user may temporarily bypass the feature if desired).

This feature should only be programmed by the installer, and the operation of this feature depends on the correct connection of the safety wire to the vehicle's parking brake. Please refer to the "Black/White wire" on pages 9 and 10 for the proper connection of this important wire.

Wiring Connections

This feature selects the RS-110-DP processor's method of determining the status of the engine running during remote start operation. As explained in feature 5's description, "Tachless" mode has an associated base starter output time duration. However, if the voltage fluctuation is detectable, the processor adjusts the starter output time accordingly. When this feature is set for "Tach Wire" operation, the base starter output increases to a maximum of 3 seconds, but the processor adjusts the actual starter engagement time accordingly. Connecting and use of the "Tach Wire" is the most reliable form of engine running information input, and its use is recommended. **Important:** Before this feature is programmed, please refer to the "Violet/White wire" section for proper wiring connection, and the Tach Learning Procedure. The "Data Tach" setting operates just like the "Tach Wire" setting except it takes its reading from the D2D data port. Use of this setting is determined by whether or not this feature is provided by the Databus Interface module. If so, the Violet/White wire is not needed nor is the Tach Learning Procedure Required. **This feature should only be programmed by the installer.**

Feature #3 Gasoline Or Diesel Engine

Factory Default Setting **Gasoline** (press brake pedal **1x** to program)
Option: **Diesel** (press brake pedal **2x** to program)

This feature changes the system's timing of the ignition and starter output sequence for remotely starting vehicles with gas or diesel engines. When set for gasoline, the starter output will occur 3 seconds after the ignitions turn on. Also, when the system is in "Tachless" mode, the engine running status will be determined 10 seconds after cranking. When set for diesel, the starter output will occur 20 seconds after the ignitions turn on to allow for glow plug warming. Also, when the system is running in "Tachless" mode, the engine running status will be determined 40 seconds after cranking. This allows the vehicle battery(s) to recharge properly and show normal voltage levels due to the heavy drain diesel engines have on the electrical system during cranking. **This feature should only be programmed by the installer.**

Feature #4 Satellite Relay Port Green Wire Function:

Factory Default Setting **Starter** (press brake pedal **1x** to program)
Options:
Pulse After Engine Start (press brake pedal **2x** to program)
Pulse After Engine Stop (press brake pedal **3x** to program)
Accessory (press brake pedal **4x** to program)

This feature changes the operation of the Green wire (negative) on the satellite relay port. This gives you the flexibility to accommodate certain vehicles that require any out-of-the-ordinary pulses or remote start timing.

- The first setting operates as a secondary START output. This will have the same pulse timing as the large Violet wire on the main harness.

- NOTE -

The following sections detail connections for each wire, of each the system's wiring harnesses. Always insure that the Black ground wire is grounded, and that the secondary wiring harness is plugged in, before connecting power circuits to the control module. The best installation procedure is to make all connections, and only then plug the individual wiring harness into the system control module.

Main Wiring Harness (LARGE 6-Wire Connector)

Red & Red/White Wires - (Constant Power Input): The Red and Red/White wires supply constant Positive 12 Volts for the system's operation. These wires must be supplied sufficient amperage.

CONNECTION: Connect these wires to Positive battery voltage; both wires must be connected. One source is the battery's Positive terminal, and another potential source is the power supply wires at the ignition switch.

If the battery is selected as the power source, and the Red and Red/White wires must be extended, the added wire must be at least the same gauge, or preferably heavier, than the Red and Red/White wires. Carefully route the wires through the firewall, using an added or existing grommet. Avoid any hot or moving parts.

Some vehicles have a single Constant 12 Volt circuit supplying the ignition switch, while others have multiple supply circuits. A schematic of the car's electrical system will show which of these is the case. The Red and Red/White wires may both be connected to a single supply wire, or distributed between multiple supply circuits.

In either case, the inline fuse holders and 30 amp fuses must be used.

If running the Red and Red/White wires to the battery or a distant power source, additional fuses must be added within 6" of the power source. The fuses that are already inline are designed to protect the control module from damage. Adding fuses at the power source will protect the vehicle's electrical system. **Caution! The use of the 30 amp fuses and inline fuse holders are required! Failure to leave these intact or changing the fuse value will void all warranties.**

Pink Wire - (Ignition #1 Input/Output): This connection is critical to the proper operation of many of the security system's features. The Pink wire is an ignition "on" input to the system and it is an output, as during remote starting operations it supplies 12 Volts Positive to the vehicle's ignition circuit.

When remote starting, this output stays active while the starter is engaged, and continues to supply power to the ignition circuit for the duration of the remote start engine run period. If the system detects a violated safety circuit, receives a transmitter command to stop running, or if the programmed run time expires, this output will stop supplying power, which stops the running engine.

CONNECTION: This wire must be connected to the vehicle's Ignition #1 (also known as Primary Ignition) wire. The proper vehicle wire will measure Positive 12 Volts when the ignition key is in the "Run" and "Start" positions and no voltage in the "Off" and "Accessory" positions. This wire is found in the ignition switch wiring harness. If two or more Primary Ignition wires are present, an optional dual relay socket with one or two relays (RS-RP) may be used via the satellite relay port to drive the additional Ignition(s). If more than three Primary Ignition wires are present, use the system's Pink/White Ignition (programmable) output wire for the second vehicle ignition.

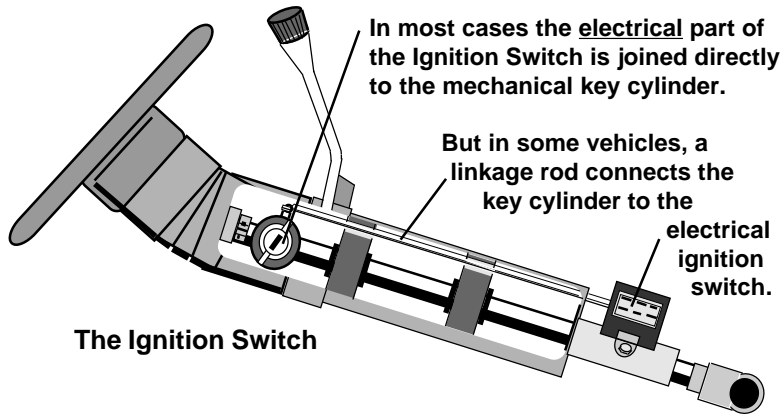

Orange Wire - (Accessory Output): The Orange Accessory wire's operation differs from the Pink Ignition #1 wire's operation. When remote starting, this output supplies 12 Volts Positive to the vehicle's chosen circuit as soon as remote starting is activated, but stops while the starter is engaged. Once the engine starts and the starter disengages, this wire returns to having 12 Volts Positive output. From this point in the remote starting cycle the Orange wire continues to

The second group of features, the Installer Programmable Features, are accessed as the second level of features' programming, which is pressing the Valet Switch 10 times instead of 5 times when entering Programming Mode (page 26). **Caution: These features have a critical affect upon the system's operations, and in many cases, also upon the system's wiring connections. These features should NEVER be changed, except by the installer or other qualified professional.** This booklet should be consulted for the proper wiring connections, as associated with these programmable features.

The Excalibur RS-110-DP's 7 **Installer Programmable Features:**

- 1 Remote Start Activation Pulses (White/Blue input wire)
- 2 "Tachless", "Tach Wire", or "Data Tach" Starter Operations
- 3 Gasoline or Diesel Engine
- 4 Satellite Relay Port Green Wire Operations
- 5 Extended Starter Cranking Times
- 6 Unlock Functions
- 7 Turbo Timer

Use the step-by-step instructions on page 30 to change any of the Installer Programmable Features, along with the feature's option choices and related programming controller/transmitter button assignment found in the following individual feature descriptions.

Feature #1 Remote Start Activation Pulses

Factory Default Setting:

1 pulse (press brake pedal 1x to program)

Options:

2 pulses (press brake pedal 2x to program)

3 pulses (press brake pedal 3x to program)

4 pulses (press brake pedal 4x to program)

This feature allows you to choose the number of pulses required on the White/Blue activation wire to activate the remote start feature. This allows you to activate the remote start with external devices. For example, you can connect this wire to a factory installed keyless entry system. You can repurpose the factory lock button so that multiple presses will activate the remote start. With any of the optional settings, each 2nd, 3rd, or 4th pulse must occur within a 5 second window of the previous pulse. **This feature should only be programmed by the installer.**

Feature #2 "Tach Wire", "Tachless", or "Data Tach" Starter Operation

Factory Default Setting

Tachless (press brake pedal 1x to program)

Options:

Tach Wire (press brake pedal 2x to program)

Data Tach (press brake pedal 3x to program)

The User Programmable Features

This group of User Programmable Features are all accessed as a group in the first level of features' programming. These features have a direct affect upon the system's operations, so the programming and operation of each are described.

The Excalibur RS-110-DP's 2 **User Programmable Features:**

- 1 Remote Start Run Time
- 2 Steady / Flashing Lights During Remote Start

Use the step-by-step instructions on page 26, and the complete features matrix on page 27, to change any of the programmable features. Each feature, the option choices and related programming controller/transmitter button assignment are described in detail in the following pages.

Feature #1 Remote Start Run Time

Factory Default Setting **10 Minutes**
(press brake pedal **1x** to program)

Options:
5 Minutes (press brake pedal **2x** to program)
15 Minutes (press brake pedal **3x** to program)
20 Minutes (press brake pedal **4x** to program)

This feature sets the period of time that the engine will run after being remotely started. If the engine is not stopped by controller/transmitter command or a safety circuit violation, the engine will automatically stop upon the expiration of the selected time period. **Caution: The remote engine starting feature should NEVER be used when the vehicle is parked in an enclosed structure or garage.**

Feature #2 Steady/Flashing Lights During Remote Start

Factory Default Setting **Steady** (press brake pedal **1x** to program)
Option: **Flashing** (press brake pedal **2x** to program)

This Feature configures the operation of the vehicle's parking lights during the remote start operation. The default setting turns on the parking lights during remote start; the other setting flashes the parking lights on and off during remote start.

The Installer Programmable Features

Installer Programmable Features should only be used by the original or other qualified installer, AND individual Installer Features should only be used, where applicable, with the correct wiring connections.

supply power to the chosen vehicle circuit for the duration of the remote start engine run period.

CONNECTION: Connect this wire to the vehicle's Accessory wire. This circuit in the vehicle can vary in its function. Typically, its primary function is to supply power to the Heat, Ventilation and Air Conditioning (HVAC) system. The connection point for this wire is also found in the ignition switch wiring harness. In some cases the correct vehicle wire will show Positive 12 Volts in the "Run" and "Accessory" ignition key positions but in other vehicles it will show the voltage only in the "Run" ignition key position. This output should not be used if the vehicle's wire also shows voltage when the ignition key is in the "Start" position.

Violet Wire - (Starter Output): When remote starting, this output supplies 12 Volts Positive to the vehicle's starter circuit. The Violet wire is best connected when installing the starter interrupt circuit. Its connection point must be on the starter side of the interrupt relay, not the Ignition Switch side. This is easily accomplished when installing the starter interrupt by combining the Violet Starter Output wire with the starter interrupt's White wire and then connecting both of these wires to the starter side of the cut vehicle wire. This is explained in further detail on the next page.

CONNECTION: The Violet wire connects to the vehicle's Starter wire, after the starter interrupt. See pages 9 & 10 for specific instructions. The vehicle starter wire will show Positive 12 Volts when the ignition key is in the "Start" position only. This wire is found in the ignition switch wiring harness, and it is important to make this connection on the ignition switch side of, and not on the starter side of, the neutral safety switch.

Some vehicles have a second Starter wire known as a "Cold Start" wire. When this second wire is present, there are several options. If the two Starter wires are the same circuit, both of them may be connected to the RS-110-DP Violet wire. If the two Starter wires are separate circuits, an additional relay may be configured, from the Satellite Relay Port; or the Pink/White ignition output may be reprogrammed as a start wire and used.

Pink/White Wire - Programmable Relay Output (default: Ignition; options: Starter or Accessory): This large Pink/White wire is the fourth of 4 onboard relays which are dedicated remote starting outputs. However, this output is different, in that it is programmable, by a jumper located on the module. This output is factory default-set for Ignition operation, or, it may be reprogrammed to operate as an Accessory output or as a Start output.

CONNECTION: As needed. If used as its default Ignition setting, connection is similar to that of the Pink ignition output wire. If it is programmed as an Accessory output, connection is similar to the Orange wire; and if programmed as a Start output, connection is similar to the that of the Violet wire.

Secondary Wiring Harness - (14-Wire Connector)

Black Wire - (Ground): The Black wire provides Negative ground for the system; proper connection of this wire is very important.

CONNECTION: Using the correctly sized crimp-on ring terminal, connect the Black wire to the metal frame of the vehicle, preferably using an existing machine-threaded fastener. Make sure that the ring terminal attached to the Black wire has contact with bright, clean metal. If necessary, scrape any paint, rust or grease away from the connection point until the metal is bright and clean. If the control module has an insufficient ground connection, the security system can find partial ground through the wires that are connected to other circuits, and function, but not correctly. As the system can partially operate, a bad ground wire connection would not likely be suspected, and in many cases a poor ground is difficult to diagnose.

Orange Wire - (Negative Output While Running); Includes wiring the thick Red & White Wires attached to the optional relay socket - (Starter Interrupt): The Orange wire is a starter interrupt output, which is active during remote start operation as an anti-starter grind feature. An optional starter interrupt socket must be added to utilize this feature.

CONNECTION: Make the starter interrupt and starter output (thick Violet wire) connections together- both connections points are related, as shown below-

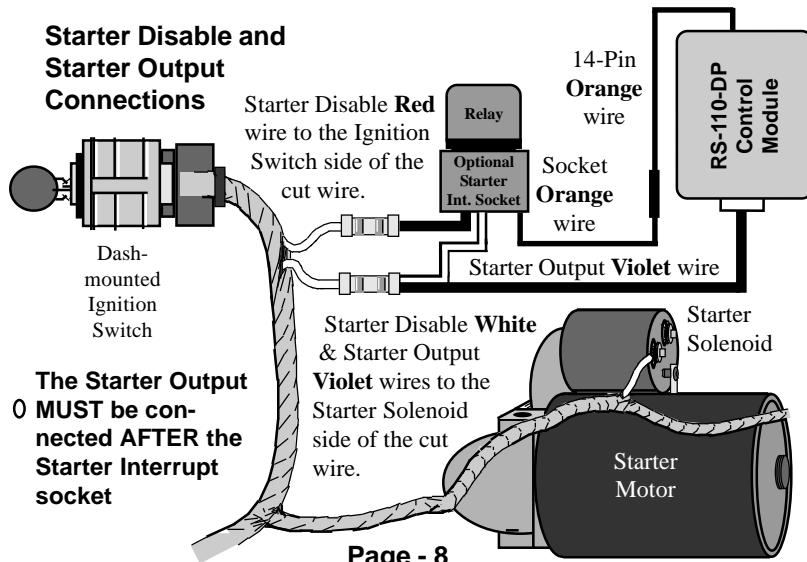

Satellite Remote Start Port Harness (Red 3-Pin Connector)

Remote Start Satellite Relay Port: This port provides for even more Ignition and Starter outputs, for remote starting use. These outputs are Negative 250mA, and the second pin is +12 Volts for the optional relay coils. A short non-terminated harness is included, to access the port, and available as an optional service part is a socket and two relays (part #RS-RP) that converts these outputs into high-amperage Positive voltage.

Blue Wire - (Negative Ignition Output): The Blue wire is a 250mA negative output that behaves exactly like the large Pink Ignition output on the main power harness. It can be used to drive relays for extra ignition outputs or to activate bypass kits via the GWR (Ground When Running) input.

Red Wire - (Constant +12V Output): The Red wire is a constant +12v, 250mA output provided to supply relays or low current devices.

Green Wire - (Negative Programmable Output): The Green wire is a 250mA negative output that is defaulted to behave exactly like the large Violet Start output on the main power harness. It can be used to drive relays for extra start outputs. This output can be programmed to give a pulse after cranking, a pulse after stopping the engine, or to behave as a negative Accessory output. Please refer to installer programmable feature #4 for more details.

Data Port (Green 4-Pin Port)

Omega data bus interface modules, and remote start bypass modules, are available as analog-operated, and as direct data-to-data (D2D) devices. The former may be operated by connection to the RS-110-DP's DLS port, or to its Satellite Relay Ports. The later are the Omega IntelliKit data bus interface modules and bypass kits, which simply plug into this Orange port. Either type of Omega accessory module includes its own vehicle-specific instructions. Please refer to the Omega website, www.caralarm.com for the latest vehicle-specific application guide. **Although other brands of data bus modules may physically plug into the RS-110-DP data port, only genuine Omega IntelliKit modules offer the highest consistent quality and dependable operation.** Always choose Omega databus product for use with this port.

- SEE PAGE 26 FOR PROGRAMMING INSTRUCTIONS -
Each of the Programmable Features is described in detail in the following pages. The User Programmable Features are described as a first group, and the Installer Programmable Features as a second group.

Yellow Wire - (External Alarm ACC Power Control): The Yellow wire is a (+) 12V output which will directly supply a host remote keyless entry or security system's ignition input circuit. This circuit has voltage whenever the ignition switch is on, but not when the RS-110-DP is in remote start mode. Connection is needed on keyless entry systems and security systems which cannot be operated if the ignition switch is on. If this circuit is not used on such a system, the alarm's transmitter, after remote start activation, would not be able to disarm/unlock or turn off the remote start.

CONNECTION: Connect the Yellow wire directly to the host unit's ignition / ACC input wire. **NOTE:** Most Omega keyless entry/alarm systems have a unique feature called "Enhanced 3rd channel" or "Remote Start Mode" which automatically disables the ACC/Ignition input during remote start. This feature eliminates the need for connecting the Yellow wire on the RS-110-DP. Please consult the installation manual of the host system before connecting.

Lt. Green/Black Wire - (Factory Disarm Output): The Lt. Green/Black wire produces a Negative pulse output whenever the RS-110-DP is unlocked or remotely starts the engine. This output may be used to disarm a factory-installed alarm, if the vehicle is so equipped.

CONNECTION: Connect this wire to the vehicle's factory disarm wire. Most commonly, the desired wire will show Negative polarity when a key is held in the "unlock" position in the door key cylinder. This wire can usually be located in either kick panel, in the wiring harness from the door, as it is routed between the door key cylinder and the factory alarm.

Lt. Green/Red Wire - (Factory Arm Output): The Lt. Green/Red wire produces a Negative pulse output whenever the system is locked or turns off the engine after having been remotely started. This output may be used to arm a factory-installed alarm, or, if the vehicle is equipped with a Retained Accessory Power circuit, this output can be used to "spike" the door pin switch wire, which will turn off the Retained Accessory Power circuit.

CONNECTION: To arm a factory alarm after remote start engine run stops, connect the Yellow/Red wire to the vehicle's factory arm wire. This wire will show Negative polarity when a key is held in the "lock" position in the door key cylinder. This wire can usually be located in either kick panel, in the wiring harness from the door, as it is routed between the door key cylinder and the factory alarm.

To use this wire to turn off Retained Accessory Power, locate the vehicle's negative doorpin wire. Should such a wire be found which is positive, a relay is needed to reverse the Lt. Green/Red wire's Negative output to Positive.

Connect the 14-pin connector's Orange wire to the Orange wire of the starter interrupt relay socket. Then make the connections which interrupt the vehicle's starter circuit- the starter wire must be located and cut. Cutting the vehicle's starter wire will result in two sides- the "ignition switch" side and the "starter solenoid" side. It is recommended that this connection be done as close to the ignition switch as possible. Use a Digital Multimeter (DMM) to find the correct wire.

CAUTION! Avoid the Airbag circuit! Especially avoid any harness or wires encased in Yellow or Red tubing or sleeves. Do not use a standard test light, as it can deploy an airbag or damage on-board computers and sensors if the wrong circuits are probed. A Digital Multimeter (DMM) should be used.

The starter wire will read Positive 12 Volts only when ignition key is in "start" position (cranking the engine). Cut this wire at a suitable location. Confirm that this is the correct wire by turning the ignition switch to the "start" position; the starter should not engage.

Connect the starter disable socket's Red wire to the ignition switch side. As mentioned in the previous section, connect both the Starter Output Violet wire and the starter disable socket's White wire to the starter solenoid side. Be sure that good, solid electrical connections are made.

Brown/Red Wire - (Positive Brake Input): The Brown/Red wire must be connected. It is a critical safety feature which disables remote starting operations whenever the brake pedal is pressed.

CONNECTION: Connect the Brown/Red wire to the brake switch wire that shows Positive 12 Volts when the brake pedal is pressed. The brake switch is typically located above the brake pedal, and usually mounted to the brake pedal support bracket. Always make this connection in a fashion ensuring its long-term reliability; soldering is highly recommended.

Always perform this test before testing the safety input (next section). Upon completing the installation, always test the Brown/Red wire's operation. Attempt to remotely start the vehicle while holding the brake pedal depressed; the system should respond with one long and four short chirps. Release the brake pedal and remotely start the engine. Once running, pressing the brake pedal should stop the engine.

Black/White Wire - (Safety Input): This circuit performs a critical safety function for remote start operations. It's connection depends on whether you plan to use the Turbo Timer feature.

STANDARD CONNECTION: The target wire will show Negative Ground whenever the gear selector is in the "Park" or "Neutral" positions, and have voltage or be neutral when it is not. The target wire is typically at an electrical switch at the shifter base or on its linkage, and once it is located and verified securely connect the Black/White wire to it.

Some vehicles do not have a grounding-type neutral safety switch, but instead route the starter circuit through a switch that is closed only when the gear selector is in the "Park" or "Neutral" positions; in other gear positions the switch is open, preventing the starter from engaging. In this type of vehicle, the Black/White wire may be connected to the parking brake warning circuit or chassis ground.

TURBO TIMER CONNECTION: The target wire must have Ground when the parking brake is applied, and either has voltage or is neutral when the parking brake is not applied. This wire is typically at a switch on the base of the parking brake lever, or on the bracket above or about the parking brake foot pedal. Securely splice the Black/White wire to the vehicle wire having the described characteristics. **Be sure to program as soon possible the Installer Feature #7 "Turbo Timer". Refer to the operation manual for programming instructions.**

Regardless of the type of connection, the vehicle must be tested to ensure that it cannot be remotely started in forward or reverse gears. Before returning the vehicle to the owner, place the vehicle in a parking lot or other open area. Sit in the driver's seat and be ready to apply the brake.

Engage the remote starter in each gear position. If this safety feature is connected properly, remote starting will only be possible if the gear selector is the "Park" or "Neutral" positions; in all other positions the system will instead respond with one long and one short chirp and the starter will not engage.

Never fail to perform this test! If a fault is found in the safety circuit operation, it must be corrected before returning the vehicle to the owner.

Violet/White Wire - (Tach-Sensing Input): The Violet/White wire is an engine speed or tachometer sensing wire. The system can use one of two different methods of monitoring the engine's starting/running status during the remote starting process- the Violet/White tach wire, and "tachless", or voltage sensing. The tach wire is typically more accurate in monitoring the engine status, and thus its use is recommended. If tach wire sensing is desired, make the proper wire connection, upon powering the unit and programming features Installer Feature #2 must be set for "Tach Wire", and then the tach wire "learn" procedure must be performed.

CONNECTION: Connect the Violet/White wire to the vehicle's tach wire, which is typically found in the engine compartment, although in some cases it may

OPTION #1

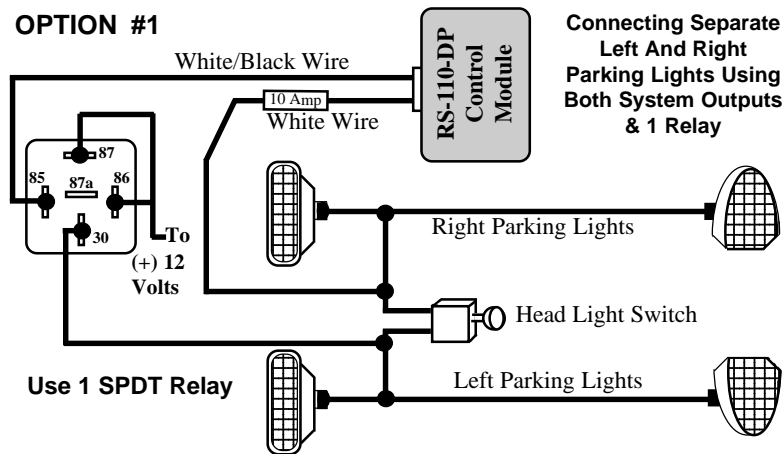

OPTION #2

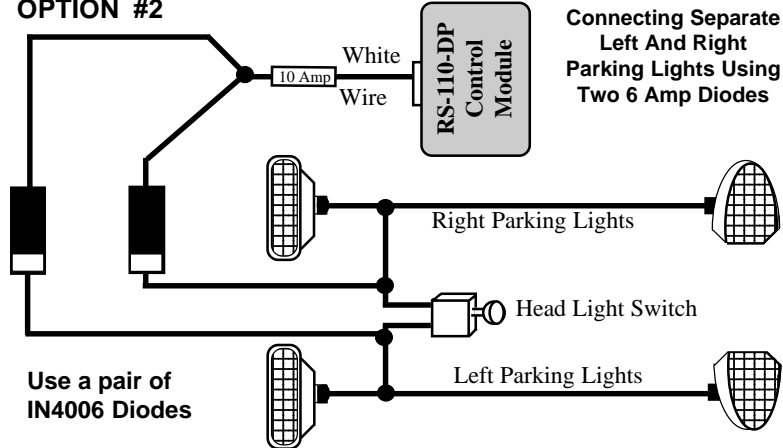

Gray Wire - Negative Instant Trigger: The Gray wire is a Negative instant trigger used primarily to detect entry into the hood area of a vehicle. **The Gray wire is an important safety circuit for remote starting operations so installation of a hood pin switch is required.**

CONNECTION: The included pin switch may be installed to provide this trigger circuit; or, if there are existing switches the Gray wire may be connected directly, provided this is a negative ground switching circuit (examples: an OEM anti-theft hood switch). An indication of such a circuit is the wire having continuity to ground when the hood is open, and up to 12 volts when the hood is closed. This wire may be also used with an optional mercury type of tilt switch.

Do not connect the White wire to a rheostated (dimmer) circuit! This will backfeed the parking lights through the rheostat or illumination control module, and possibly cause damage to the vehicle or security system control unit. Flashing the headlights is not recommended.

Another cautionary note is that the halogen headlights found in modern vehicles are not designed to be rapidly turned on and off, and if connected to the security system, a reduction of their useful life may occur. If flashing the headlights is still desired, a relay must be used, since the headlight's current draw exceeds the 10 amp rating of the built-in relay. If flashing headlights and parking lights are desired, use two relays - configure one relay to supply the parking lights and the other relay to supply the headlights.

Caution: Do not connect to the dimmer circuit!
Damage can occur to the unit & the vehicle.

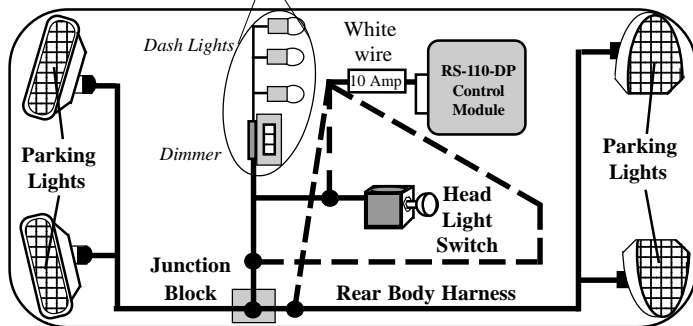

Recommended Connection Points For The White Wire

White/Black Wire - (Negative Flashing Light Output): This wire has the exact same operation as the White Positive Parking Light wire, except that it is Negative polarity output instead of Positive.

CONNECTION: If the vehicle has a parking/head light switch which switches Negative instead of Positive voltage to operate the parking lights, connect this wire to the vehicle's wire which shows the change to Negative when the parking lights are turned on.

MULTIPLE PARKING LIGHT CONNECTIONS: Many European imports have separate left and right side parking lights. On these cars or others having dual parking light circuits, there are two options available to the installer described on the next page:

also be located inside the vehicle. **Caution! Route this wire carefully to prevent its possible shorting to ground.** To use a multimeter to verify the correct tach wire, set it for AC Volts scale. The correct wire will read 1 to 6 volts AC with the engine idling, and the reading will increase when engine speed (RPM) increases.

TACH LEARNING PROCEDURE: As mentioned, the tach wire method is typically more accurate in monitoring the engine status, and a special "learning procedure" programs the tach signal to the RS-110-DP. The tach learning procedure should be performed after the installation has been completed, but before activating the remote start feature. To perform the procedure:

- Step 1** Turn the ignition switch "on", then "off".
- Step 2** Within 5 seconds, press the brake pedal 5 times.
- Step 3** Start the engine.
- Step 4** When the Status Light turns On the tach signal is learned. Turning the ignition "off" or pressing the brake removes the unit from tach learning mode.

Note: This unit must learn the normal idle RPM. If the engine RPM level is above normal idle after initially starting, it may be necessary to disconnect the tach wire until after Step 3 **AND** after the engine has settled at a normal idle (around 700 RPM). Reconnect the tach wire at this point to ensure ideal tach learning.

White/Blue Wire - (Remote Start External Activation Input): If the White/Blue wire receives a Negative pulse the remote start operation will be activated. Even if this wire is used to activate remote starting, the transmitter or transceiver's normal button assignment will also operate remote starting.

CONNECTION: Connect the White/Blue wire directly any output which gives a Negative pulse.

White Wire - (Positive Flashing Light Output): This is a Positive 12 Volt output to flash the vehicle's parking lights for visual arming confirmation, to illuminate them for disarming confirmation, to confirm remote starting, and to attract attention while the system is activated. **The RS-110-DP also has a Negative version of this wire- see the following White/Black wire description.**

CONNECTION: Connect this wire to the vehicle's Positive 12 Volt parking light circuit, which can usually be found at the following locations: at the headlight switch, at the fuse/junction block, or in the rear body harness in the driver kick panel. Some vehicles have a parking light relay which is triggered by a Negative Ground circuit from the headlight switch; for these vehicles, use the White/Black Negative Flashing Parking Light output wire instead.

The correct wire will show Positive 12 Volts when the headlight switch is in the "Parking Light" and "Head Light" positions. When such a wire is located, also test to ensure that it is non-rheostated: meter the wire operate the dash light dimmer control; the correct wire will show no voltage change when the dimmer is operated.

RS-110-DP Wiring Diagram Overview

