

# K-9

## K9-Classic-EDP

**BACK COVER  
PRINTER'S NOTE:  
production back cover  
is to be printed with gray  
scale front cover; this is a  
place marker cover.**

## INSTALLATION INSTRUCTIONS

**FRONT COVER  
PRINTER'S NOTE:  
production front cover  
is gray scale; this is a  
place marker cover.**

# Contents

Wiring Diagram Overview .....	18-19
Installation Considerations .....	3-5
<i>Status Light &amp; Valet Switch</i>	

## Wiring Connections

Main Wiring Harness .....	6-8
Secondary Wiring Harness .....	9-15
<i>Smart Trigger</i>	

## Accessory Connections

DLS Power Doorlock Port.....	16-17 & 20-21
Backup Battery Port .....	21
Sensor Port .....	21-22
Data Port .....	22
Factory Alarm Arm/Disarm, Options Port .....	22

## Programming

The Programmable Features .....	23-31
Programming Features .....	32
Programmable Features Matrix .....	33

The K9-Classic-EDP's transmitters are pre-programmed at the factory to operate the system. If adding or replacing transmitters or controllers, **please see the Operation Guide booklet for Transmitter programming.**

**Omega** Disclaims Any Responsibility or Liability In Connection With Installation.

**- IMPORTANT -**

***Please carefully read these instructions before starting the installation of the K9-Classic-EDP security system. The numerous wiring connections required, and the options offered by several of the programmable features makes pre-planning the installation critical.***

***More complete instructions for programming transmitters and features may be found in the Operation Guide manual.***

## ***Installation Considerations***

**Before Starting The Installation:** This entire booklet should be read before starting the installation. An understanding of which control module wires are to be used and their functions is essential. Installations will vary from car to car, as some control module wire connections are required, while others are optional. Before starting the installation, it should be determined which control module wires will be used. Most installers will list these wires, then "map out" the installation by locating and noting the target wires in the vehicle. This will also determine the best location for the control module, which is mounted upon completion of the installation and testing of the system.

Some of the wiring connections, such as power, ignition and starter interrupt, are best made at the ignition switch harness, located around the steering column area.

**CAUTION! Avoid the Airbag circuit! Especially avoid any harness or wires encased in Yellow or Red tubing or sleeves. Do not use a standard test light, as it can deploy an airbag or damage on-board computers and sensors if the wrong circuits are probed. A Digital Multimeter (DMM) should be used.**

Other typical connection points may be behind the dash or in the kick panel areas, for parking and/or interior lights, trigger circuits and power doorlocks. Soldering or proper use of crimping terminals for all wiring connections are recommended.

## Complete Programmable Features Matrix

**Mounting The Control Module:** The Control Module contains the necessary electronics required for the system's operation. Always mount this module in the vehicle's interior compartment, in a secure location that is not easily accessible. Ensure that moisture, vibration and temperature extremes are minimized. Acceptable locations include mounting behind the dash, behind the glovebox or other interior panels.

**Mounting The Electronic Siren:** The electronic “2-n-1 Psycho Siren” must be mounted external to the vehicle but not accessible or vulnerable to tampering. Locations in the engine compartment typically offer the best mounting opportunities. See page 9 for specific mounting and connection details.

**Status Light and Valet Switch:** The Status Light may be custom-mounted inside the vehicle by drilling a 9 / 32” hole in a suitable interior panel; be sure to carefully ensure that the area behind the location has an unobstructed depth of at least 1/2”. Then route the wiring harness through the hole to the control module, and snap the light in place. Mount the valet switch, using its adhesive pad, in a hidden location which is accessible to the operator; carefully route the wires to the control module.

Or, use the combination holder for the Status Light and Valet Switch. Mount the assembly in a location where it can easily be seen by the driver, and preferably where it can be seen from outside. Two mounting methods are provided: double-sided adhesive tape, and two screws. If using the adhesive tape, properly prepare the mounting surfaces to ensure good adhesion. If using the screws for a more permanent mounting, carefully separate the housing halves, install the screws (avoid overtightening), then snap the assembly halves back together. Carefully route the wiring harness to the control module to avoid any chances of it being chafed or pinched.

**Power Doorlock Options:** The K9-Classic-EDP has the flexibility of these options for interfacing a vehicle’s power doorlocks.

**DLS Port-** This option is the traditional “DLS” port, which can direct-wire basic 3-wire Negative pulse doorlocking systems, and accept all Omega analog doorlocking accessories (dual, triple relay sockets, or the modular clip-on add-on relay packs). All Omega doorlocking data bus module accessories can be driven by either this port, and the DLS port offers two unlocking outputs, so that driver’s door priority unlocking can be configured. See pages 16-21 for basic wiring diagrams.

**Data Port for IntelliKit Modules & Bypasses:** Omega IntelliKit data bus interface modules and bypass kits simply plug into this port. These data-to-data (D2D) accessory products save time, and in many cases offer the only acceptable interface means for many newer vehicle’s doorlocking system and/or for the OEM-antitheft bypass when adding an alarm or an optional accessory remote start module

Features		Ignition on, off, then press Valet Switch 5 times (Status Light turns on steady)			
#	Feature	Default Setting	Option	2nd Option	3rd Option
1	SecureCode	1 & 0	2 stages, of up to 9 presses each (total of 99 possible combinations)		
2	Last Door Arming	OFF (L)	ON w/o doorlock (U)	ON w/ doorlock (2)	
3	Automatic Rearming	OFF (L)	ON w/o doorlock (U)	ON w/ doorlock (2)	
4	Starter Interrupt Functions	Alarm only (L)	Off (U)	Automatic (2)	
5	Ignition Activated Override	OFF (U)	ON (L)		
6	Doors Lock With Ignition On	ON (L)	OFF (U)		
7	Doors Unlock With Ignition Off	ON (3)	OFF (L)	o/p 1 only (U)	o/p 2 only (2)
8	Open Door Bypass to above	ON (L)	OFF (U)		
9	Confirmation Chirps	ON (L)	OFF (U)	exc. Valet (2)	Valet only (3)
10	Confirmation Chirp Volume	Medium Loud (2)	Low (L)	Med Lo (U)	Loud (3)
11	Activated Alarm Cycle	30 Seconds (L)	60 Sec. (U)	90 Sec. (2)	120 Sec. (3)
12	Lights On Upon Disarm	ON (L)	OFF (U)		
13	Disarm Upon Trunk Release	ON (L)	OFF (U)		
14	Arming Delay	3 Seconds (L)	15 Seconds (U)	30 Seconds (2)	45 Seconds (3)
15	Steady Siren / Pulsed Horn	Steady Siren (L)	Pulsed Horn Lo (U)	Pulsed Med. (2)	Pulsed Hi (3)
16	Alarm Functions Bypass	OFF (U)	ON (L)		
17	Ignition Anti-Carjacking	OFF (U)	ON (L)		
18	Door Anti-Carjacking	OFF (U)	ON (L)		
19	Remote Anti-Carjacking	OFF (U)	ON (L)		
20	Open Door Warning at Arm	OFF (U)	ON (L)		
21	Ill Button Operation	Panic (L)	3rd Chan. (U)	4th Chan. (2)	5th Chan. (3)
22	Doorlock Functions	.8 second (L)	3 Seconds (U)	Double Unlock (2)	Total Closure (3)
23	Factory Alarm Arm Output	Arm (L)	Parking Light (U)	Chan. 4 Latch (2)	Chan. 4 On Demand (3)
24	Factory Alarm Disarm Output	Disarm (L)	Horn, med (U)	Chan. 5 Latch (2)	Chan. 5 On Demand (3)

# Programming Features

## Enter Programming mode:

- |               |  |
|---------------|--|
| <b>Step 1</b> | Turn the vehicles's ignition on.   |
| <b>Step 2</b> | Turn the ignition off.   |
| <b>Step 3</b> | <u>Within 5 seconds</u> , Press & Release the Valet Switch <b>5</b> times. <ul style="list-style-type: none"><li>• The siren will chirp then sound briefly and the Status Light will light steady to confirm that the system is entering Programming Mode.</li></ul> |

## Access a Feature:

- |               |  |
|---------------|--|
| <b>Step 4</b> | <u>Within 10 seconds</u> , Press & Release the Valet Switch the same number of times as the desired feature's number. <ul style="list-style-type: none"><li>• The siren will chirp and the Status Indicator Light will flash off the same number of times as the Valet Switch was pressed to indicate the feature number accessed.</li></ul> |
|---------------|--|

## Change the Feature:

- |               |  |
|---------------|--|
| <b>Step 5</b> | After accessing the desired feature, <u>within 10 seconds</u> Press & Release the appropriate controller or transmitter button. <ul style="list-style-type: none"><li>• Pressing the “<b>arm/lock</b>” button typically turns the feature on; or sets the feature's first option. The siren will chirp once when this button is pressed.</li><li>• Pressing the “<b>disarm/unlock</b>” button also typically turns the feature off; or, sets the feature's second option. The siren will chirp twice.</li><li>• Many features have third, and even fourth setting options. Pressing the “<b>I</b>” and “<b>III</b>” buttons select these options. Confirmation chirps when these buttons are pressed are three and four chirps respectively.</li></ul> |
|---------------|--|

## To Access and Change further Features:

- |               |  |
|---------------|--|
| <b>Step 6</b> | If there are more features to be programmed, <u>within 10 seconds</u> of the previous action Press & Release the Valet Switch the same number of times as the next desired feature's number. <ul style="list-style-type: none"><li>• Again the siren will chirp and the Status Indicator Light will flash as many times as the Valet Switch was pressed to indicate the new feature number which is now accessed. Then use the controller or transmitter as described in Step 5 to change the newly accessed feature as desired.</li></ul> |
|---------------|--|

## Exit Programming mode:

- |               |  |
|---------------|--|
| <b>Step 7</b> | Allow 10 seconds to pass without performing any programming actions, or turn the vehicle's ignition on. <ul style="list-style-type: none"><li>• The siren will sound briefly and the Status Indicator Light will go out.</li></ul> |
|---------------|--|

with the K-9 system. Omega offers the industries most comprehensive line of these products (go to [www.caralarm.com](http://www.caralarm.com) for latest application guide), and each includes its own vehicle-specific instructions. Also see page 22.

**Backup Battery:** The K9-Classic-EDP has backup battery capability. If the system loses vehicle power it will revert to operating with basic security functions, if the backup battery is installed. See page 21 for installation details.

**Auxiliary Sensor Port:** The K9-Classic-EDP includes an impact sensor which conveniently plugs directly into an auxiliary sensor port. All Omega sensors are fully compatible with the K-9's sensor port. An available Sensor Expansion Module (AU-EXP) allows plug-in usage of multiple sensors. See page 21.

**Programmable Outputs:** The K9-Classic-EDP also has two additional Negative outputs which are programmable. As received they are dedicated “arm” and “disarm” outputs to control an existing OEM alarm, but if desired these can be used for a horn output, flashing light output or 4th and 5th remote channel outputs.

**Coaxial Antenna Cable:** When installing the K9-Classic-EDP control module, unbind the Black coaxial antenna cable, and route the exposed inner end high in the dash or behind pillar trim for the best operating range. Do not place the exposed end too close to metal structural parts of the vehicle.

The K9-Classic-EDP can be upgraded to be a two-way system by the addition of an optional Echo 2-way kit. In this case, a window-mounted transceiver unit plugs into the 5-pin Echo port, replacing the jumper plug. When the Echo is used the coaxial antenna cable is no longer used; it may be left in place or unplugged and removed.

# Wiring Connections

## - NOTE -

The following sections detail connections for each wire, of each system's wiring harnesses. Always insure that the Black ground wire is grounded, and that the secondary wiring harness is plugged in, before connecting power circuits to the control module. The best installation procedure is to make all connections, and only then plug the individual wiring harnesses into the system control module.

## Main Wiring Harness (5-Wire Connector)

**Black Wire - (Ground):** The Black wire provides Negative ground for the system; proper connection of this wire is very important.

**CONNECTION:** Using the correctly sized crimp-on ring terminal, connect the Black wire to the metal frame of the vehicle, preferably using an existing machine-threaded fastener. Make sure that the ring terminal attached to the Black wire has contact with bright, clean metal. If necessary, scrape any paint, rust or grease away from the connection point until the metal is bright and clean. If the control module has an insufficient ground connection, the security system can find partial ground through the wires that are connected to other circuits, and function, but not correctly. As the system can partially operate, a bad ground wire connection would not likely be suspected, and in many cases a poor ground is difficult to diagnose.

**Red Wire - (Constant Power Input):** The Red wire's function is to supply Constant Positive 12 Volts for security system's operation. When 12 Volts is first applied to the Red wire, the system will revert to the state in which it was in when power was taken away. If the vehicle to be serviced, especially if it involves the battery, the system should be placed in Valet Mode. This will prevent the system from being activated if the battery is disconnected and reconnected. The Red wire also supplies 12 Volt Positive to the module's internal relay for flashing the parking lights.

**CONNECTION:** Connect the Red wire to a Constant Positive 12 Volt source. This source should have Positive 12 Volts with at least a 15 Amp capacity at all times and in all ignition key positions. Connection locations can be at the supply wire at

pressing the "arm/lock" or "disarm/unlock" button. Only the output itself will stop- pressing either button again will normally operate the system, and at any time after the 28 second lock output period ends.

If either of the programmable outputs are set for lock or unlock operation (the next two Programmable Features), the settings if this feature will operate the programmable outputs accordingly, in addition to the system's primary DLS port doorlocking outputs.

## Feature #23 Factory Alarm Arm Output Functions

<b>Factory Default Setting</b>	<b>Arm Output</b> (press "arm/lock" button to program)
--------------------------------	---

### Options:

<b>Parking Light Output</b>	(press "disarm/unlock" button to program)
<b>Channel 4 Latch Output</b>	(press "II" button to program)

<b>Channel 4 On Demand Output</b>	(press "III" button to program)
-----------------------------------	---------------------------------

The default setting of this feature is to arm the factory alarm when the K-9 is armed. Options for this output are a (-) Negative flashing parking light output, which is more frequently encountered in newer vehicles. Other options are an additional remote output, operated by the transmitter's "arm/lock" and "II" buttons together, and in two forms of operation: "Latch", in which the output toggles (i.e.- turns on and turns off) with each buttons press, and "On Demand" which is output occurring while the buttons are being pressed. Feature #21 can change this channel's button assignment.

## Feature #24 Factory Alarm Disarm Output Functions

<b>Factory Default Setting</b>	<b>Disarm Output</b> (press "arm/lock" button to program)
--------------------------------	--

### Options:

<b>Horn Output</b>	(press "disarm/unlock" button to program)
--------------------	---

<b>Channel 5 Latch Output</b>	(press "II" button to program)
-------------------------------	--------------------------------

<b>Channel 5 On Demand Output</b>	(press "III" button to program)
-----------------------------------	---------------------------------

The default setting of this feature is to disarm the factory alarm when the K-9 is disarmed. Other options for this output are very popular application, operating the vehicle's existing horn; either in conjunction with the electronic siren, or in place of the siren. Using both the siren and the horn creates an extremely effective security system, and be configured in many vehicles without further parts. The remaining options are Channel 5, with the same operation parameters as described above for Channel 4, except that the "disarm/unlock" and "III" buttons operate it, and Feature #21 can also change this channel's button assignment.

**CAUTION! Do not exceed the output capacities of either wire- both outputs are rated at (-) Negative 250mA.**

- Options:**
- 3rd Channel** (press “**disarm/unlock**” button to program)
- 4th Channel** (press “**II**” button to program)
- 5th Channel** (press “**III**” button to program)

This feature changes how the controller’s or transmitter’s “**III**” button operates. Normal operation, or the default setting, has the “**III**” button operate the Panic feature. This feature allows changing it to instead operate the 3rd channel or either of the two other optional channel outputs (see the Complete Programmable Features Matrix on page 33). Panic can still be operated, by the alternative methods of pressing either the “**arm/lock**” and “**disarm/unlock**” button for 3 seconds.

## Feature #22 Doorlocking Functions

**Factory Default Setting** **.8 Second Lock & Unlock Output**  
 (press “**arm/lock**” button to program)

- Options:**
- 3 Second Lock & Unlock Output** (press “**disarm/unlock**” button to program)
- Double Pulse Unlock Output** (press “**II**” button to program)
- Total Closure Lock Output** (press “**III**” button to program)

This single feature gives the installer several needed options, to match the security system’s doorlocking outputs to suite different vehicle requirements.

- The first setting (programmed by the “**arm/lock**” button) has the system produce both the lock and unlock outputs as .8 second in duration. This is the most common form of output needed, which interfaces most vehicles.
- The second setting (programmed by the “**disarm/unlock**” button) changes the lock and unlock outputs to be a longer 3 second pulse output. This is for certain vehicles which require a longer output pulse from the system’s control unit; typically cars having vacuum pump systems, although the longer setting is also more suitable in some newer vehicles.
- Some newer vehicles require a double pulse output to remotely unlock the doors and/or to disarm a factory-equipped security system, which is what the Double Pulse Unlock setting provides (it is programmed by the “**II**” button ). The lock output pulse, in this setting, is .8 second.
- The Total Closure Lock Output (programmed by the “**III**” button) may be used with vehicles which are originally equipped with the total-closure feature. Typically, a total closure feature is when locking the vehicle’s doors if the key in the door is held to “lock” for a period of time the vehicle will close all windows and the sunroof, in addition to locking the doors. Selecting this feature setting changes the system’s door lock output pulse from a .8 second to as long as a 28 second duration output. The unlock output is 3 seconds in this setting.

**Note:** When this feature is turned on, during the 28 second period after arming the system, the lock output can be stopped on demand by the user by

the ignition switch, the supply wire *behind* the fuse block or the fuse/junction block. *Never* just insert the Red wire or any other security system wire behind a fuse. Also, please note that connecting directly to the battery’s Positive terminal will expose this connection to failure due to a corrosive environment unless the connection has a protective coating.

**Yellow Wire - (Ignition Input):** The Yellow wire is an ignition "on" input to the security system. This connection is critical to the proper operation of many of the security system's features.

**CONNECTION:** This wire supplies Positive 12 Volts to the control module whenever the ignition switch is "on". This connection should be made at the ignition switch harness, to the primary ignition circuit. Primary ignition has 0 Volts when the ignition key is in the "Lock", "Off" and "Accessory" positions; and Positive 12 Volts in the "Run" and "Start" positions. Locate the correct wire at the ignition switch harness and securely splice the Yellow wire to it.

**Orange Wire - (Negative Output While Armed); Includes the thick Red & White Wires attached to the relay socket - (Starter Interrupt):** The Orange wire is a starter interrupt output, which is active when the security system is in an armed state; the relay that it is attached to the Orange wire prevents the starter from engaging, if a starting attempt is made while the system is armed.

**CONNECTION:** The typical starter interrupt is shown here-

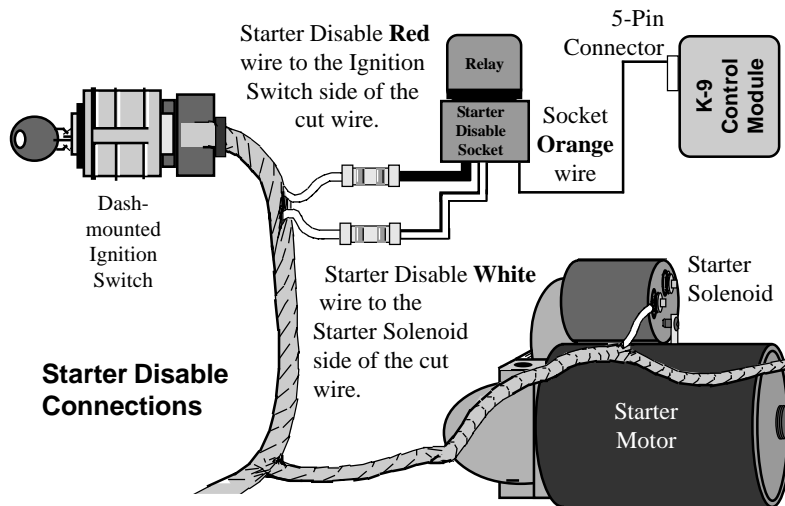

The starter wire must be located and cut. Cutting the vehicle's starter wire will result in two sides- the "ignition switch" side and the "starter solenoid" side. It is recommended that this connection be done as close to the ignition switch as possible. Use a Digital Multimeter (DMM) to find the correct wire.

**CAUTION! Avoid the Airbag circuit! Especially avoid any harness or wires encased in Yellow or Red tubing or sleeves. Do not use a standard test light, as it can deploy an airbag or damage on-board computers and sensors if the wrong circuits are probed. A Digital Multimeter (DMM) should be used.**

The starter wire will read Positive 12 Volts only when ignition key is in "start" position (cranking the engine). Cut this wire at a suitable location. Confirm that this is the correct wire by turning the ignition switch to the "start" position; the starter should not engage.

Connect the starter disable socket's Red wire to the ignition switch side. Connect the starter disable socket's White wire to the starter solenoid side. Be sure that good, solid electrical connections are made.

**Gray Wire - (2nd Channel or Negative Trunk Release Output):** The Gray wire is an optional output operated by the controller/transmitter "II" button; typically the primary use is for trunk release.

**CONNECTION:** If the vehicle's existing trunk release switch operates as switching Negative to activate trunk release, and draws 250mA or less, the Gray wire may connected directly to the vehicle's switch output wire. If the target wire is Positive switching, and/or draws more than 250mA, an optional relay must be used. To configure a relay to the Gray wire, connect it to relay pin (85), and connect Constant Positive 12 Volts to relay pin (86). Connect pin (30) to power, or ground, as needed. Pin (87) is then connected to the vehicle's trunk wire. **See the Universal Relay Diagram on page 22.**

siren requires. When programming this feature for using the output for the vehicle's horn, the optional setting produce pulsed output on the system's siren wire, in three different pulse timings, which allow a degree of customizing of the horn's sound during the alarm activation.

### Feature #16 Alarm Functions Bypass

**Factory Default Setting** Off (press "disarm/unlock" button to program)

**Option:** On (press "arm/lock" button to program)

This feature converts the system into a strictly Remote Keyless Entry System by eliminating all anti-theft alarm-oriented operations and features. When this feature is programmed on, the K-9 has remote keyless entry operation only.

### Feature #17 Ignition Activated Anti-Carjacking Protection

**Factory Default Setting** Off ( "disarm/unlock" button to program)

**Option:** On (press "arm/lock" button to program)

This form of Anti-Carjacking is initiated by the ignition key being turned on. All 3 forms of Anti-Carjacking protection are described in the Operation Guide.

### Feature #18 Door Activated Anti-Carjacking Protection

**Factory Default Setting** Off (press "disarm/unlock" button to program)

**Option:** On (press "arm/lock" button to program)

This form of Anti-Carjacking is initiated by a door being opened. All 3 forms of Anti-Carjacking protection are described in the Operation Guide.

### Feature #19 Remote Activated Anti-Carjacking Protection

**Factory Default Setting** Off (press "disarm/unlock" button to program)

**Option:** On (press "arm/lock" button to program)

This form of Anti-Carjacking is initiated by a signal from the controller or transmitter. All 3 forms of Anti-Carjacking protection are described in the Operation Guide.

### Feature #20 Open Door Warning Upon Arming

**Factory Default Setting** Off (press "disarm/unlock" button to program)

**Option:** On (press "arm/lock" button to program)

When this feature is turned on, if one of the vehicle's doors is open at the time that the system is armed via the controller or transmitter, the siren will chirp 3 times and the parking lights will flash 3 times instead of once.

### Feature #21 "III" Button Operation

**Factory Default Setting** Panic  
(press "arm/lock" button to program)



time. If this feature is turned off, the parking lights flash once only, and do not illuminate. This feature only affects the K-9's parking light operation, and not the interior light operation.

### Feature #13 2nd Channel Also Disarms System

**Factory Default Setting**    **On** (press "arm/lock" button to program)  
**Option:**                        **Off** (press "disarm/unlock" button to program)

"2nd channel" is most commonly used to remotely open the vehicle's trunk, in which case the alarm should also disarm. This feature, turned on, configures the system to disarm when the 2nd channel is used. If turned off, the 2nd channel output will still occur, with 2 chirps, but without the parking light flashes; and if armed, the system will not disarm.

### Feature #14 3 or 45 Second Arming Delay

**Factory Default Setting**    **3 Seconds**  
(press "arm/lock" button to program)

**Options:**

**15 Seconds**                    (press "disarm/unlock" button to program)  
**30 Seconds**                   (press "II" button to program)  
**45 Seconds**                   (press "III" button to program)

When the system is armed, whether by the controller, transmitter or by an automatic feature, there is a brief period of time in which a system activation, or alarm, cannot occur. This Arming Delay allows the system to completely process its sensory parameters, which can include the vehicle to stabilize. In some cases more time is needed than the factory-set 3 seconds, and this feature offers three longer delay options.

### Feature #15 Steady Siren or Pulsed Horn

**Factory Default Setting**    **Steady Siren**  
(press "arm/lock" button to program)

**Options:**

**Pulsed Horn Low**            (press "disarm/unlock" button to program)  
**Pulsed Horn Medium**        (press "II" button to program)  
**Pulsed Horn High**            (press "III" button to program)

It is important to understand that the K9-Classic-EDP has a primary audible output, for the electronic siren; and that it also has a programmable output which among its applications is being used to sound the vehicle's existing horn. This feature changes only the primary audible output, so that it can be utilized to sound the existing horn by itself with an added relay to either reverse the polarity to (-) Negative or as a higher (+) Positive amperage which can be connected directly to the vehicle horn.

The Steady Siren setting is exactly that- a steady output which the electronic

## Secondary Wiring Harness (8-Wire Connector)

**Brown Wire - (Positive Siren Output):** The Brown wire is a 1 Amp Positive output designed to operate the electronic siren for audible confirmations, and to sound if the alarm is triggered.

**SIREN CONNECTION:** The Brown wire may be connected directly to the siren's Red wire, and the siren's Black wire is connected to (-) Ground.

**SIREN MOUNTING:** Find a location in the engine compartment away from the extreme heat of the engine and manifold. A suitable location will offer a firm mounting surface, will also allow sound dispersion out of the engine compartment, and not be accessible to a thief. The siren must be pointed downward to avoid moisture getting inside it and to enhance sound dispersal.

**SIREN CHIRPS:** The siren itself can be set for loud or less loud confirmation chirps- cut the short Black wire loop on the siren for louder confirmation chirps. The confirmation chirps volume may also be adjusted to four different volume levels by User Programmable Feature #10. User Programmable Feature #9 turns the chirps off completely, or it can also set the system to only chirps in valet mode, or to chirp except when the system is in valet mode.

**HORN CONNECTION:** The K9-Classic-EDP can sound the vehicle's existing horn in addition to, or in place of, the electronic siren.

Sounding the horn alone can be accomplished by one of these means:

- 1) Use this Brown wire. Change Feature #15 to one of the "Pulsed" output settings, and typically use a relay to convert the Brown wire to Negative, or higher output, to connect to the vehicle's horn relay wire or horn wire directly.
- 2) If the Factory Alarm Disarm function is not needed, program Feature #24 for the "horn" setting and connect the Yellow/Green output wire to the vehicle horn relay wire; or, add a relay to the Yellow/Green wire to switch higher amperage Positive or Negative directly to the horn.

See the Universal Relay Diagram on page 22.

**HORN & SIREN CONNECTION:** The K9-Classic-EDP can also sound the siren and horn together. Connect the Brown wire to the siren and connect the Yellow/Green wire to vehicle horn as described above.

**CAUTION! Do not exceed the output capacities of either wire- the Brown siren wire is 1 Amp, Positive output; and the Yellow/Green programmable horn wire output is Negative 250mA.**

**White Wire - (Positive Flashing Light Output):** This is a Positive 12 Volt output to flash the vehicle's parking lights for visual arming confirmation, to illuminate them for disarming confirmation, to confirm remote starting, and to attract attention while the system is activated.

**CONNECTION:** Connect this wire to the vehicle's Positive 12 Volt parking light circuit, which can usually be found at the following locations: at the headlight switch, at the fuse/junction block, or in the rear body harness in the driver kick panel. Some vehicles have a parking light relay which is triggered by a Negative Ground circuit from the headlight switch; for these vehicles, simply find the Positive output side of the stock relay for a direct connection; or, instead of this White wire use the Yellow/Red wire programmable output in its "parking light" setting.

The correct wire will show Positive 12 Volts when the headlight switch is in the "Parking Light" and "Head Light" positions. When such a wire is located, also test to ensure that it is non-rheostated: meter the wire operate the dash light dimmer control; the correct wire will show no voltage change when the dimmer is operated.

**Do not connect the White wire to a rheostated (dimmer) circuit!**  
 This will backfeed the parking lights through the rheostat or illumination control module, and possibly cause damage to the vehicle or security system control unit. Flashing the headlights is not recommended.

**Another cautionary note** is that the halogen headlights found in modern vehicles are not designed to be rapidly turned on and off, and if connected to the security system, a reduction of their useful life may occur. If flashing the headlights is still desired, a relay must be used, since the headlight's current draw exceeds the 10 amp rating of the built-in relay. If flashing headlights and parking lights are desired, use two relays - configure one relay to supply the parking lights and the other relay to supply the headlights.

When this feature is used to remove these chirps, the system will still have 3 chirps upon arming if a protected zone is violated, and still have 4 chirps upon disarming if the system was previously activated. Using this feature to turn off the arm and disarming chirps will also not affect the Prewarning operation, Unauthorized Transmitter Alert (if used), nor will it affect the chirps used when programming.

The other two settings will have the confirmation chirps operate only when the system is in Valet Mode, and not otherwise; or, the chirps will operate except when the system is in Valet Mode.

### Feature #10 Confirmation Chirp Volume

- |                                |  |
|--------------------------------|--|
| <b>Factory Default Setting</b> | <b>Medium High</b><br>(press "II" button to program) |
| <b>Options:</b>                |  |
| <b>Low (softest)</b>           | (press "arm/lock" button to program)                 |
| <b>Medium Low</b>              | (press "disarm/unlock" button to program)            |
| <b>High (loudest)</b>          | (press "III" button to program)                      |

This feature allows the choice of four different volume levels of the system's confirmation chirps, and when programming it, the buttons can be repeatedly and sequentially pressed, thus making it easy to hear and choose the setting with the best chirp volume. This feature operates regardless of how feature #15, "Steady Siren" or "Pulsed Horn" is set.

### Feature #11 Alarm Duration

- |                                |   |
|--------------------------------|---|
| <b>Factory Default Setting</b> | <b>30 Seconds</b><br>(press "arm/lock" button to program) |
| <b>Options:</b>                |   |
| <b>60 Seconds</b>              | (press "disarm/unlock" button to program)                 |
| <b>90 Seconds</b>              | (press "II" button to program)                            |
| <b>120 Seconds</b>             | (press "III" button to program)                           |

This feature allows four choices of the Alarm Duration, which is the period of time for which the system sounding the siren (and/or horn, optionally) and flashes the parking lights when it is triggered. **Caution: Before lengthening the Alarm Duration you should always check and determine if there are any local anti-noise or nuisance ordinances to avoid the possibility of the system user receiving a violation citation.**

### Feature #12 Parking Light Illumination Upon Disarm

- |                                |  |
|--------------------------------|--|
| <b>Factory Default Setting</b> | <b>On</b> (press "arm/lock" button to program)       |
| <b>Option:</b>                 | <b>Off</b> (press "disarm/unlock" button to program) |

This feature affects the parking light operation when the system is disarmed. When this feature is turned on, the parking lights flash once, and then turn back on for external illumination for 30 seconds unless the ignition key is turned on during that

**Caution: Do not connect to the dimmer circuit!**  
 Damage can occur to the unit & the vehicle.

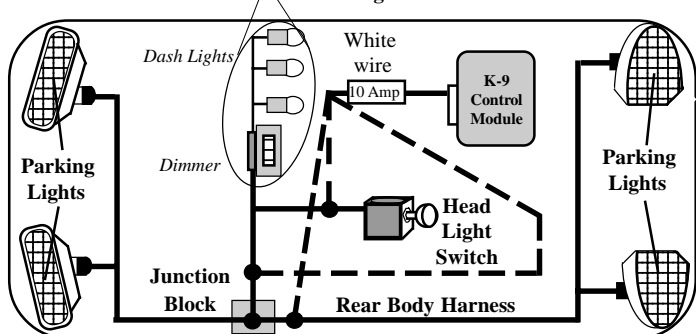

**Recommended Connection Points For The White Wire**

time that the ignition switch is turned on. An exception to this would be if feature #8 is turned on, and a door being open when the ignition switch is turned on. The following feature #7 controls the automatic unlocking operations, and feature #8 provides for an override of this automatic locking if a door is open when the ignition is turned on.

### Feature #7 Doors Unlock With Ignition Off

**Factory Default Setting**    **On (all doors will unlock)\***  
 (press “III” button to program)

- Options:**
- Off** (press “arm/lock” button to program)
  - Driver’s Door Only\*** (press “disarm/unlock” button to program)
  - All Doors Except Driver’s Door\*** (press “II” button to program)

Similar to the previous locking feature, except this feature controls the unlock operations when the ignition is turned off, and it has more options because of the multiple unlocking outputs of the DLS port.

\*Multiple unlock outputs offer the capability of unlocking only the driver’s door when the system is disarmed (Driver Door Priority Unlocking), and then the option of unlocking all doors with a second press of the “disarm/unlock” button. **The driver’s door unlocking differently from the other doors must be configured when the system is installed!**

If the system is installed without the Driver’s Door Priority Unlocking interface, this feature unlocks all of the doors when the ignition switch is turned off. If Driver’s Door Priority Unlocking is installed, this feature can control only the driver’s door unlocking when the ignition is turned, all doors unlocking, or all doors except the driver’s. The following feature provides for an override of this automatic unlocking if a door is open when the ignition is turned off.

### Feature #8 Open Door Bypass of Ignition Locking

**Factory Default Setting**    **On** (press “arm/lock” button to program)

**Option:**    **Off** (press “disarm/unlock” button to program)

This feature cancels the automatic locking or unlocking of the vehicle’s doors should one of the doors is open when the ignition switch is turned on or off.

### Feature #9 Confirmation Chirps

**Factory Default Setting**    **On**  
 (press “arm/lock” button to program)

- Options:**
- Off** (press “disarm/unlock” button to program)
  - Chirps Excepting Valet Mode** (press “II” button to program)
  - Chirps in Valet Mode Only** (press “III” button to program)

This feature removes the system’s 1 arming and 2 disarming confirmation chirps.

**Green Wire - (Negative Door Trigger):** The Green wire is an "open door" input to the control module for vehicles having *Negative switching* door pin switches. This wire is most commonly connected to the vehicle interior light system.

### Typical Negative Switching Interior Light System

The Driver Pin Switch will often have an extra wire that activates the “ignition key in switch” warning chime. This circuit will activate the security system, but only from the driver’s door, and is the incorrect trigger wire >

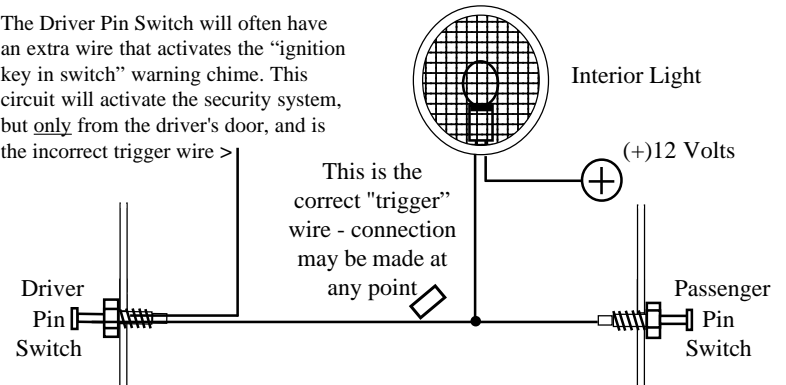

**CONNECTION:** Connect the Green wire to a wire in the vehicle that is common to all the door pin switches; the correct wire in this type of interior or dome light/door jamb pin switch system will have no voltage present and will also show chassis ground when the doors are opened, and up to 12 volts when the doors are closed.

**Violet Wire - (Positive Door Trigger):** The Violet wire is identical to the Green Door Trigger wire, with the sole exception that it is an open door input to the control module for vehicles having *Positive 12 volt* door pin switches.

### Typical Positive Switching Interior Light System

**Note:** The Driver Pin Switch will often have an extra wire; this circuit will activate the security system, but only from the driver’s door. This is the incorrect activation wire >

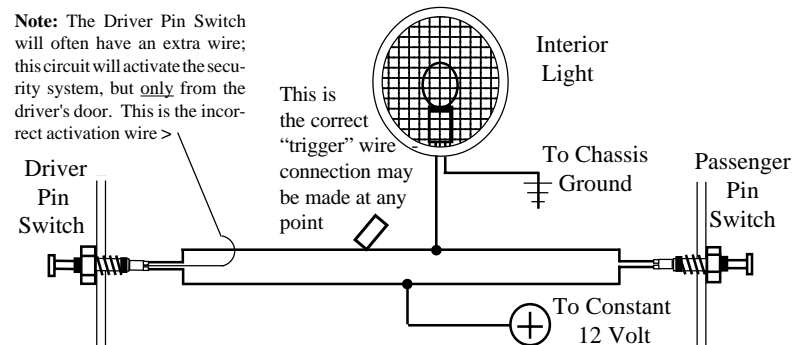

The correct wire for a Positive switching type of dome light/door jamb pin switch system will have 12 volts present when the doors are opened, and chassis ground when the doors are closed.

**CONNECTION:** Connect the Violet wire to a wire in the vehicle that is common to all the door pin switches; the correct wire for this type of dome light/door jamb pin switch system will have 12 volts present when the doors are opened, and chassis ground when the doors are closed.

#### **Notes and Tips, both types of Interior Light or Door Trigger**

**circuits:** The correct wire will show this change when any of the doors are opened. If the vehicle has delay-off or “fade away” interior lights, remember to take this into account when testing the wire. If the pin switch is mounted in the metal structure of the vehicle, and the interior lighting goes out when the switch is removed, suspect a grounding switch-type lighting system.

Switches controlling interior lighting may be found in several locations- the front or rear door jamb area, as the traditional “pin switch” or sliding switch; or as switches inside the doors, either connected to the exterior door handles or to the latching mechanism. A vehicle which has the interior lights illuminating when the outside door handle is lifted is an example of this type of switching system.

Also be aware of vehicles which diode-isolate each door. Typically, this is usually encountered with dash displays that indicate individual doors being ajar. The proper wire to connect to in this type of system is the common wire which is routed directly to an interior light that illuminates when any door is opened.

### **Green/Violet - (Domelight Supervision Output) & Black/Red - (Domelight Supervision Input) Wires:**

Domelight Supervision offers an additional safety and security feature- upon disarming the system the interior lights will turn on to illuminate the interior. The Green/Violet wire is the output to turn on the lights, and the Black/Red wire is input, connected to Positive or Negative polarity which is needed for operating the interior light.

For reference, see the diagrams on the previous page showing the basic differences between Negative and Positive interior light circuits.

**CONNECTION GREEN/VIOLET:** The proper vehicle wire to connect the Green/Violet wire to, the dome light activation wire, is common to all the door pin switches. The correct wire will change polarity as the doors are opened and closed.

**The dome light activation wire in the vehicle is typically the same wire that the**

### **Feature #3 Automatic Rearming**

**Factory Default Setting** Off  
(press “arm/lock” button to program)

#### **Options:**

**On without doors locking** (press “disarm/unlock” button to program)

**On with doors locking** (press “II” button to program)

“Automatic Rearming” prevents the system from becoming accidentally disarmed by having it arm itself after being disarmed, if a door is not then opened or the ignition turned on. Options are to have Automatic Rearming operate with or without also locking the doors when the system does rearm.

### **Feature #4 Starter Interrupt Functions**

**Factory Default Setting** On  
(press “arm/lock” button to program)

#### **Options:**

**Off** (press “disarm/unlock” button to program)

**Automatic** (press “II” button to program)

This feature controls the Starter Interrupt circuit, in several ways. In its default setting, “On”, the Starter Interrupt is operable whenever the alarm is armed.

The “Automatic” option will cause the Starter Interrupt output to automatically engage 90 seconds after the ignition switch is turned “off”, and also 90 seconds after disarming the system. This automatic engagement will occur even if the security system is in a disarmed state, but not if it is in Valet Mode. Once the Starter Interrupt output is activated, the system must be armed, then disarmed with the controller or transmitter, or placed into the Valet Mode by pressing and holding the Valet Switch for 2 seconds to disengage it. There are no Status Light indications with this automatic form of Starter Interrupt.

Programming this feature “Off” completely eliminates the Starter Interrupt output, while leaving all other system operations fully functional.

### **Feature #5 Ignition Activated Override**

**Factory Default Setting** Off (press “disarm/unlock” button to program)

**Option:** On (press “arm/lock” button to program)

This feature allows an activated system to be overridden and disarmed by simply turning the ignition switch on within 10 seconds of the system’s activation. After 10 seconds, the Emergency Override must be performed or the controller or transmitter “disarm/unlock” button can be used to disarm the system.

### **Feature #6 Doors Lock With Ignition On**

**Factory Default Setting** On (press “arm/lock” button to program)

**Option:** Off (press “disarm/unlock” button to program)

This feature configures the system to automatically lock the vehicle’s doors every

## Feature #1 SecureCode

Factory Default Setting 1 Press

### Options:

1 to 9 presses, in each of two stages

SecureCode is a unique patented feature which allows the user to custom select the number of Valet Switch presses in two stages, instead of a single "1 press", which would be required in order to perform an Emergency Override. If any of the three anti-carjacking features are utilized, a customized SecureCode would also be required to turn the alarm off once it is fully activated. The SecureCode operation is described in detail the Operations Guide.

### To custom program a new SecureCode:

**Step 1** Follow Steps 1 to 4 in the previous "How to Program Features" instructions; at Step 4 the Valet Switch will be pressed and released once (the siren chirps once) to access "feature #1".

**Step 2** Within 10 seconds slowly press and release the controller or transmitter's "arm/lock" button the number of times equal to the desired SecureCode for stage 1, allow the system to respond to each controller/transmitter button press with a siren chirp before pressing the button again.

**Step 3** After entering the first stage by pressing the "arm/lock" button the desired number of times, and receiving a chirp for each press, wait for the system, after the final button press, to chirp the siren again the total number of times that the button was pressed.

**Step 4** Continue to configure stage 2 of the SecureCode by now pressing and releasing the "disarm/unlock" button the number of times desired for the stage 2. This should be done in the exact same fashion as the stage 1 entry-press the "disarm/unlock" button, wait for a single chirp before pressing the button again, and then when final button press is done, wait after the single chirp for the siren to chirp the total number entered Valet Switch entry.

## Feature #2 Last Door Arming

Factory Default Setting Off

(press "arm/lock" button to program)

### Options:

**On without doors locking** (press "disarm/unlock" button to program)

**On with doors locking** (press "II" button to program)

"Last Door Arming" has the system automatically arm itself every time the operator exits the vehicle and closes the door. This feature turns that operation on or off, and with options of having Last Door Arming operate with or without also locking the doors when the system does arm.

## Green or Violet wire is connected to, for the door trigger.

If the vehicle uses a Negative switching interior light system, the activation wire will have no voltage present and show chassis ground when the doors are opened, and up to 12 volts when the doors are closed. The correct wire for a Positive switching type of interior light/door jamb pin switch system will have 12 volts present when the doors are opened, and chassis ground when the doors are closed. The correct wire will show these changes when any of the doors are opened. If the vehicle has delay dome lights, remember to take this into account when testing.

**CONNECTION BLACK/RED:** The polarity of the dome light supervision output must be selected by the connection of the Black/Red wire as Positive or Negative. Connection of the Green/Violet should have determined which polarity the vehicle uses to operate the dome light; this is either "Negative switching" or "Positive switching" (see the diagrams on page 11). Once "Positive switching" or "Negative switching" has been determined, connect the Black/Red wire to Negative (for "Negative switching" interior lights) or to Positive (for "Positive switching" interior lights).

**"Smart Trigger":** The K9-Classic-EDP has a unique "Smart Trigger" feature which saves installation time while offering enhanced integration flexibility. The Green/Violet Domelight Supervision output wire has an additional function; it can also be used as a door trigger input circuit, serving the same purpose as either the Green or Violet door trigger wires.

If the Smart Trigger feature is used, **it is not necessary to connect either the Green Negative Door Trigger or the Violet Positive Door Trigger wire, provided the Green/Violet Domelight Supervision output wire is connected correctly.**

### CONNECTION:

#### Negative Dome Light Smart Trigger Connection

The Smart Trigger jumper must be set for (-) Negative polarity

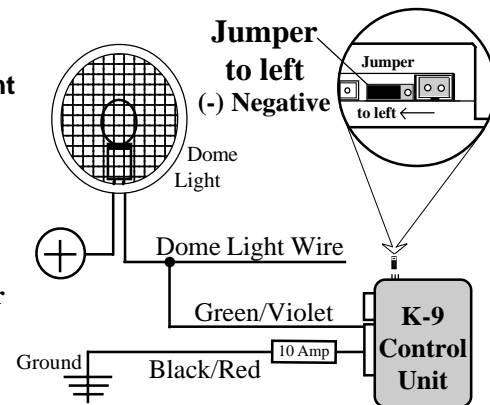

## Positive Dome Light Smart Trigger Connection

The Smart Trigger jumper must be set for (+) Positive polarity

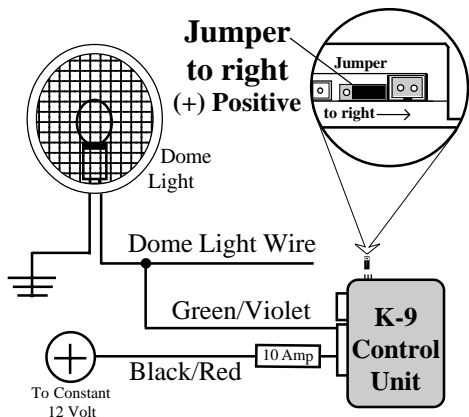

The Smart Trigger feature may be used or not used, as desired by the installer. If Smart Trigger is utilized, please note that **the polarity must be programmed** (via the jumper connector on the side of the control module) for "positive switching dome light" or "negative switching dome light".

**If use of the Smart Trigger feature is not desired, remove completely the polarity selection jumper. Doing so separates the dome light supervision circuit from the door trigger circuits.** The Black/Red and Green/Violet wires may then be connected for the Domelight Supervision only, and either the Green Negative Door Trigger or the Violet Positive Door Trigger wire must be connected for the system's door trigger. In some cases, when opting for automatic rearming or last door arming, it may be preferable to not use the Smart Trigger, and connect the appropriate door trigger wire for the best operation of the automatic arming or rearming feature.

**Blue Wire - (Negative Instant Trigger):** The Blue wire is a Negative instant trigger used to detect entry into the hood or trunk area of a vehicle.

**CONNECTION:** The included pin switches may be installed to provide this trigger circuit; or, if there are existing switches the Blue wire may be connected directly, provided this is a negative ground switching circuit (examples: an OEM antitheft hood switch, or in the case of the trunk or hatch a light in the luggage compartment or a "Trunk Ajar" light in the dash).

An indication of such a circuit is the wire having no voltage present when the hood or trunk is open, and up to 12 volts when the hood or trunk is closed. This wire

- SEE PAGE 32 FOR PROGRAMMING INSTRUCTIONS -

Each Programmable Features is described in detail in this section, then Programming instructions follow, which include a handy Features' matrix showing the Features and all programming options.

## The Programmable Features

This group of User Programmable Features are all accessed as a group in the first level of features' programming. These features have a direct affect upon the system's operations, so the programming and operation of each are described.

The K9-Classic-EDP's **24 Programmable Features:**

- 1 SecureCode
- 2 Last Door Arming
- 3 Automatic Rearming
- 4 Starter Interrupt Functions
- 5 Ignition Activated Override
- 6 Doors Lock With Ignition On
- 7 Doors Unlock With Ignition Off
- 8 Open Door Bypass To Previous Two Features
- 9 Confirmation Chirps
- 10 Confirmation Chirp Volume
- 11 Activated Alarm Cycle
- 12 Lights On Upon Disarm
- 13 Disarm Alarm Upon Trunk Release
- 14 Arming Delay
- 15 Steady Siren Output / Pulsed Horn
- 16 Alarm Functions Bypass
- 17 Ignition Activated Anti-Carjacking Protection
- 18 Door Activated Anti-Carjacking Protection
- 19 Remote Activated Anti-Carjacking Protection
- 20 Open Door Warning Upon Arming
- 21 Ill Button Operation
- 22 Doorlock Functions
- 23 Factory Alarm Arm Output
- 24 Factory Alarm Disarm Output

Use the step-by-step instructions on page 42, and the complete features matrix on page 43, to change any of the programmable features. Each feature, the option choices and related programming controller/transmitter button assignment are described in detail in the following pages.

## Data Port (Green 4-Pin Port)

Omega data bus interface modules, and remote start bypass modules, are available as analog-operated, and as direct data-to-data (D2D) devices. The former may be operated by connection to the DLS port. The later are the Omega IntelliKit data bus interface modules and bypass kits, which simply plug into this Green port. Either type of Omega accessory module includes its own vehicle-specific instructions. Please refer to the Omega website, [www.caralarm.com](http://www.caralarm.com), for the latest vehicle-specific application guide. **Although other brands of data bus modules may physically plug into the K9-Classic-EDP data port, only genuine Omega IntelliKit modules offer the highest consistent quality and dependable operation.** Always choose Omega databus products for use with this port.

## Arm/Disarm, Options Port (Orange 2-Pin Connector)

This Orange 2-pin port has a pair of outputs, Factory Arm and Disarm, which are also programmable for several other functions (see Features #23 and #24). These are 250mA (-) Negative outputs. Use a relay if needed to increase these outputs or reverse their polarity.

**CAUTION! Do not exceed the output capacities of either wire—both outputs are rated at (-) Negative 250mA.**

### Universal Relay Diagram

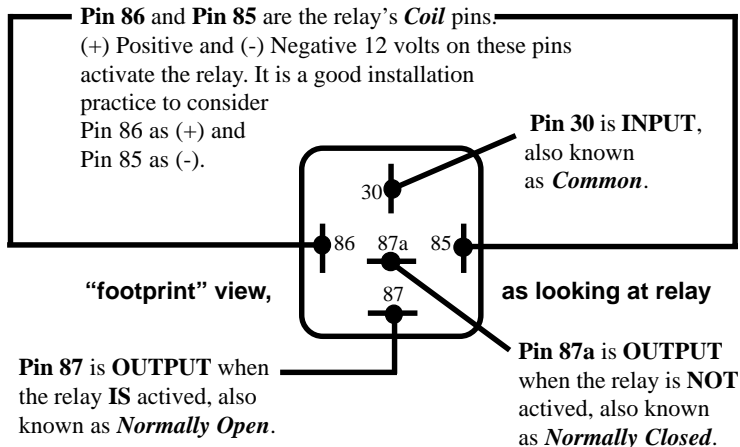

may be used with a mercury type of tilt switch, by itself, but it cannot be used with existing hood or trunk lights which have an internal mercury switch. If the vehicle is equipped with a usable trunk or hood circuit, locate the proper wire and splice the Blue wire directly to the vehicle's wire. If not, then you can install a pin or mercury switch and carefully adjust and test it.

**Multiple use of the Blue wire:** When wiring more than one of the vehicle's circuits and/or additional circuits to this wire, diode-isolation is usually required to maintain each circuit's proper independent operation. An example would be wiring a hood pin switch and trunk light switch together. Without isolating, the trunk light will illuminate whenever the hood is raised. Also, diode-isolation is necessary when combining electronic sensors together, or when adding a sensor in the same circuit as the pin switches.

### Diode-Isolating Multiple Negative Instant Triggers

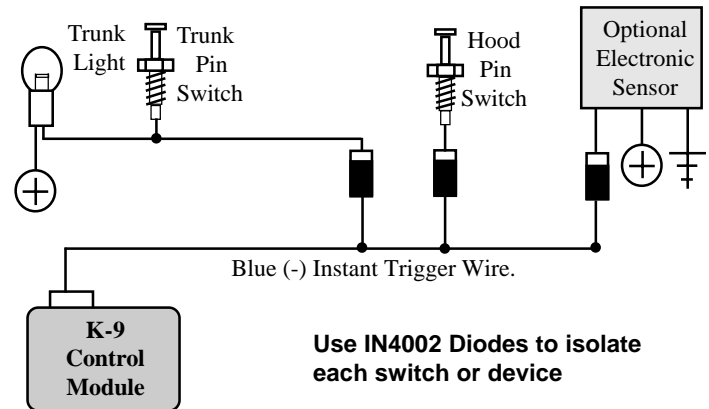

**Pink Wire - (Negative 3rd Channel or Option Output):** The 3rd Channel Pink wire is an optional output similar to the 2nd Channel Gray trunk or hatch release wire; however, this output is not capable of disarming the system when it is used and therefore has no audible or visual confirmation.

**CONNECTION:** For most applications an optional relay will be needed; typical connection is the Pink wire to relay pin #85, and connect Constant Positive 12 Volts to relay pin #86. Connect pin #30 to power, or ground, as needed. Pin #87 is the output, and connected to the target wire. **See the Universal Relay Diagram on page 22.**

## Accessory Wiring Harness - DLS Port (Red 4-Pin Connector)

**Plug-In DLS Power Doorlock Interface Port:** The Red 4 pin port on the system's control module produces a negative pulse output for locking the doors, a constant 12 volt pin for the optional relay coils only, a first negative pulse output for driver door unlock, and a second negative pulse output for unlocking all other doors.

The vast majority of power doorlocks are found as three system types: 3 wire negative pulse, 3 wire positive pulse and 5 wire reversal, rest at ground. Other power doorlock systems which may be encountered are the vacuum pump types found in older Mercedes vehicles and the single wire, dual-voltage which has appeared in some late model vehicles. The best way to identify a doorlock system is to examine the doorlock switch's wiring.

**3 Wire Negative Pulse Systems** are typically indicated by the presence of three wires at the switch. Of these, one will show constant ground, regardless of whether the switch is being operated or not (at rest); one will show ground when the switch is pushed to the "lock" position, and the other wire will show ground when the switch is pushed to the "unlock" position. With the switch at rest, these two wires will read voltage, usually 12 volt positive but in some cases less. The wires from the switches operate doorlock relays or a doorlock control unit with built-in relays; make the connections between the switches and the relays.

**CONNECTION:** The included harness (DLP-N4) can allow direct connection between the security system and a 3-Wire Negative Pulse system. If more than the 500mA Ground output that the security module can provide is required, use the optional model DLS and two relays. When driver's door unlock priority is desired, use the optional DLS-3.

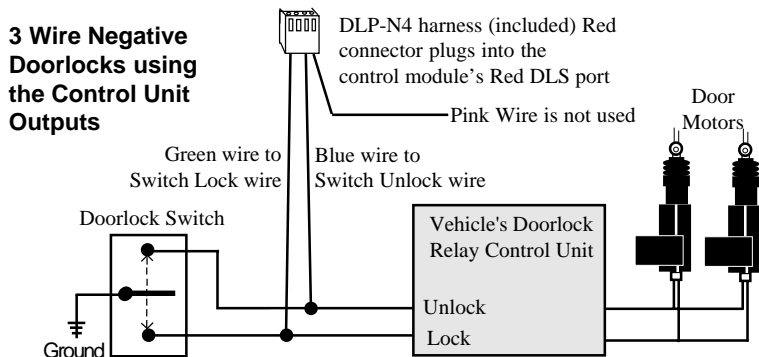

The two later wires are both routed to the doorlock actuators and are connected to either end of the actuator's motor winding. When the switch is pushed to one position, one of these two wires will have 12 volts. This voltage flows through the wire to the actuator's motor winding, and since the other wire is still resting at ground an electrical circuit is completed. When the switch is pushed to the opposite position the electrical flow is reversed.

Once determined, the correct wires must be cut. Notice in the diagram that the driver's switch is the primary switch and referred to as the "switch" wires. The wires that go to the secondary switch are referred to as the "motor" wires. Even though the cut is made between the switches, the two sides are still correctly called the "switch" and the "motor" sides, with consideration of "Primary" and "Secondary" switch.

## Backup Battery Port, Harness and Bracket (White 2-Pin Connector)

The K9-Classic-EDP features backup battery capability. Included with each is a slide-on clip mounting bracket and a snap-cap wiring harness for an optional alkaline 9 volt battery. If the alkaline 9-volt battery is used, it should be replaced with a fresh battery about every year for best system backup performance.

Also available is an optional rechargeable battery pack, which if used would be a permanent backup power supply, not requiring occasional replacement.

To add the backup battery feature:

- 1) Assemble the backup pack (instructions are with the bracket and harness) with an optional alkaline 9-volt battery, slide the assembly onto the alarm control module, and then plug the 2-pin wiring harness into the White 2-pin port on the module.  
**OR**
- 2) Or if the optional rechargeable pack is chosen, it is pre-assembled and be attached to the alarm control module in the same fashion, by sliding it onto the control module. Insert the battery pack's 2-pin plug into the alarm's White backup battery port, and connect its remaining single Red wire directly to Constant (+) Positive 12 volts.

## Sensor Port (White 4-Pin Port)

Install the included impact sensor according to the instruction sheet included with it, and then plug its wiring harness into the alarm control module's White 4-pin port (be cautious to not plug the White sensor connector into the Red DLS doorlock output port).



**5 Wire Reversal Rest At Ground Systems** differ from the Negative and Positive Pulse systems as there are no relays or doorlock control unit. In this type of system, the switches themselves supply the positive voltage directly to the doorlock actuators, and, more importantly, provide the return ground path. The important thing to remember is the wires in this system *rest at ground*, which means that the wires must be "opened", or cut, to make the connections.

Examine the wires on the back of the switch. Normally five wires will be found- one will be constant 12 volts positive, regardless of the switch's position; two wires will be grounded regardless of the switch's position. Of the two remaining wires, one will show 12 volts positive when the switch is pushed to "lock", and the other will show 12 volts positive when the switch is pushed to "unlock".

### 5 Wire Reversal Doorlocks using the Optional DLS & 2 Relays

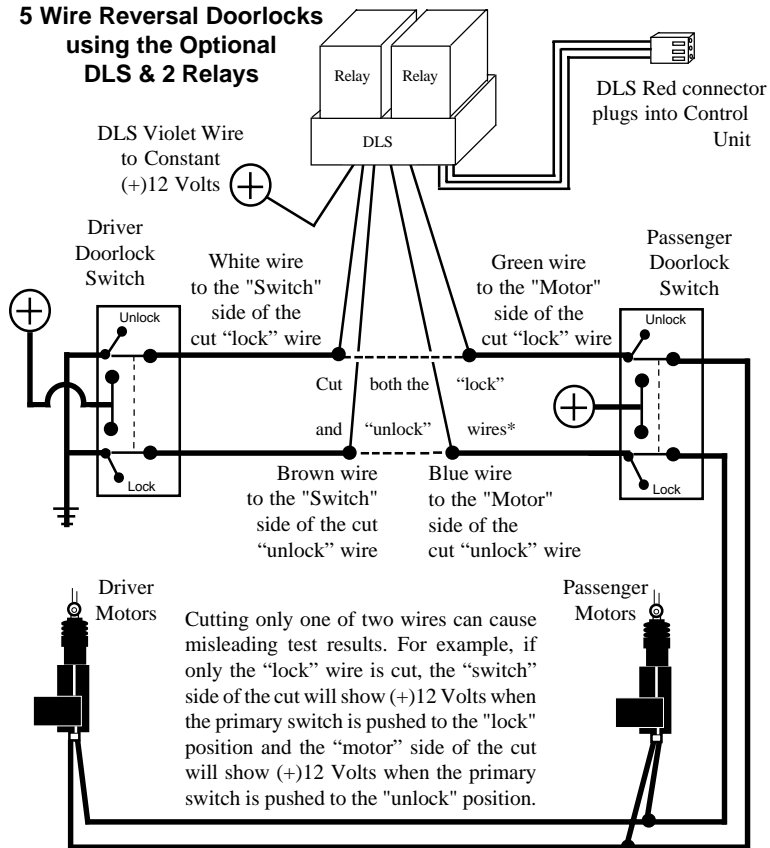

**3 Wire Positive Pulse Systems** are very similar to the Three Wire Negative Pulse system except the vehicle's doorlock switches use 12 volt positive pulses to operate the vehicle's doorlock relays or control unit. Examine the three wires on the back of the switch; **if more than three, suspect a 5 Wire Reversal system**. One will be constant 12 volt positive, regardless of the switch's position. Of the two remaining wires, one will show Positive when the switch is pushed to "lock", and the other will show Positive when the switch is pushed to "unlock".

**CONNECTION:** Several options are available for connecting to 3 Wire Positive Pulse doorlocking systems- the DLP-P3 polarity reversal interface, the DLS and two relays or the DLR-C or DLR-U. If driver's door unlock priority is desired, use the optional DLS-3. The following diagrams show how to connect either of the optional DLP-P3 or the DLS and 2 relay interfaces.

### 3 Wire Positive Pulse Doorlocks using an Optional DLP-P3 Polarity Converter

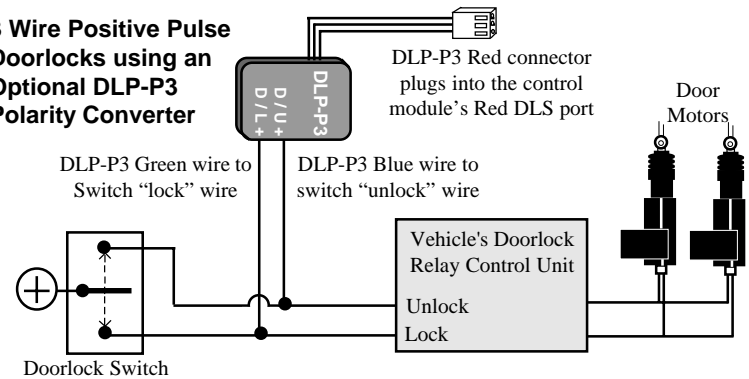

### 3 Wire Positive Pulse Doorlocks using an optional DLS & 2 SPDT Relays

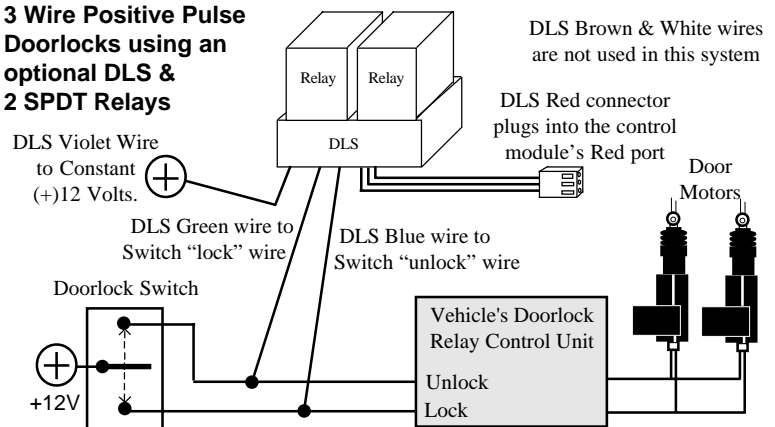

# Wiring Diagram Overview

**Note:** The K9-Classic-EDP may be upgraded to 2-way operation by an optional Omega Echo kit.

